

**Dantherm**<sup>®</sup>  
CLIMATE SOLUTIONS



2022

## **CLIMATE CONTROL**

FOR POOLS, SPAS, LEISURE CENTRES AND COMMERCIAL BUILDINGS

DANTHERMGROUP

## About the Dantherm Group

Originally founded in 1954, the Dantherm Group is a European leader in portable and installed climate control solutions for a wide range of industries and uses. Based on the work of more than 500 passionate climate control experts and more than three million installations, our competence centres around Europe design and build exceptional heating, cooling, dehumidification and ventilation units that form the backbone of these climate solutions. In everything they do, they remain focused on creating healthy and comfortable climate surroundings in a sustainable, energy-efficient and cost-effective way.



Five competence centres in Denmark, Germany, Italy, Spain and UK.



**Competence centre**  
for air handling and dehumidification:  
Skive, Denmark.



### **Pool & Commercial**

Established in 1958 and home to Dantherm Group's biggest manufacturing facility, the competence centre in Skive, Denmark, is highly specialised in the development of high-end air handling and dehumidification solutions. Renowned for their energy efficiency, durability and low lifecycle costs, the solutions are suitable for all pool sizes.



# CONTENT

Based on the extensive knowhow of our climate solution experts across the Group, we have developed an industry-leading range of products and solutions all characterised by reliability, sustainability, efficiency and ease of use.

Being able to source everything from just one supplier will help streamline your purchasing supply lines and reduce your costs for internal handling. To that end, you'll also find our local presence with an extensive network of professional dealers across Europe helpful. It means support in your time zone and language – from people who understand your local market requirements.

Enjoy the read!

Our solutions rest on these four pillars:

**Reliability** has always been at the heart of everything we do. So we still use long-lasting, solid components that have been through extensive testing.

**Sustainability** is an integral part of how we work. We aim to create solutions that are at least as good for the environment as any comparable solution.

**Efficiency** is about delivering impressive performance while generating savings in the form of reduced energy costs.

**Usability** is key to any solution. Our experts do many usability tests to make sure ours are easy to install and hassle-free to operate.



SWIMMING POOL  
DEHUMIDIFIERS

**P6**



SWIMMING POOL  
HEAT PUMPS

**P18**

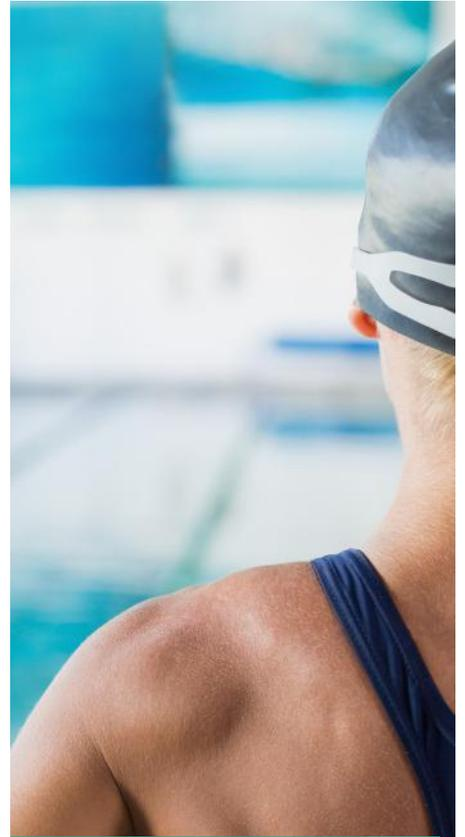

SWIMMING POOL  
AIR HANDLING  
UNITS

**P26**



CONDENSE  
DEHUMIDIFIERS

**P44**



ADSORPTION  
DEHUMIDIFIERS

**P57**



ACCESSORIES

**P68**

# SWIMMING POOL DEHUMIDIFIERS

When moisture is left unchallenged, this can present a major problem for an indoor pool.

Not only does it create an uncomfortable atmosphere for swimmers and bathers, but encourages mould growth and structural damage that can leave your pool area looking less than luxurious. Our pool dehumidifiers physically remove moisture from the air to ensure the environment stays controlled and your home pool projects are protected.



# DEHUMIDIFICATION SOLUTIONS FOR: PRIVATE AND COMMERCIAL SWIMMING POOLS

## QUICK GUIDE



CDP 40-50-70



CDP 40T-50T-70T



CDP 75-125-165



DANX AF

### POOL TYPE



INDOOR



### INSTALLATION



WALL-MOUNTED



THROUGH-THE-WALL



FLOOR-STANDING



DUCTED



### APPLICATIONS



PRIVATE POOLS



SPA & THERAPY



HOLIDAY PARKS &  
CAMPSITES



HOTELS, SCHOOLS &  
HEALTH CLUBS



# WALL-MOUNTED/FLOOR-STANDING SWIMMING POOL DEHUMIDIFIERS

## CDP 40-50-70



**CDP 70**

The wall-mounted or floor-standing CDP 40-50-70 condensation dehumidifiers have been designed to blend well with any modern pool interior. Offering energy-efficient and near-silent humidity control, the units were conceived with a view to quality and ease of operation. Combined with highly efficient fans and compressors, the advanced remote control and monitoring options contribute to cost-efficient operation and significant energy savings.

The range is also available in wall-mounted or floor-standing versions.

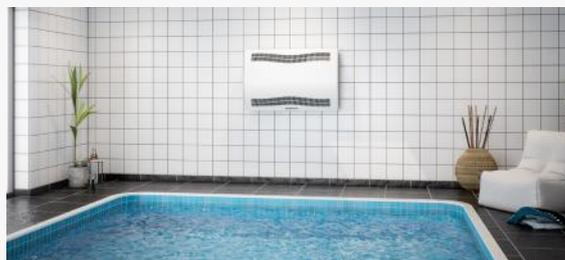

- Low sound level
- Low energy consumption
- Evaporator and condenser coils are epoxy coated
- Metal parts are powder coated before assembly
- Optional remote control
- Integrated control of heating and humidity (ON/OFF)
- BMS Communication (Modbus)
- 230 V connection for exhaust fan , control valve and pump

### Optional accessories



**Wireless remote control DRC1-093455**



**Floor mounting kit - 094322**



**Water heating coils - 094333, 094334, 094335**



**Control valve for water heating coil - 094340**



**Electric heating coils - 094336, 094337, 094338**



**Exhaust fans - 094339**



**External RH/t sensor - 051710**

Specifications	Units	CDP 40	CDP 50	CDP 70
Operating temperature range	°C	10-36	10-36	10-36
Operating humidity range	% RH	40-100	40-100	40-100
Dehumidification @ 28°C/60% RH	l/24h	34	52	69
SEC @ 28°C/60% RH	kWh/l	0.47	0.48	0.43
Air flow	m³/h	400	680	900
Sound pressure level	dB(A)	46	47	50
R407c gas weight/CO <sub>2</sub> equivalent	kg/t	0.7/1.24	0.9/1.60	1/2/2.13
Power supply	V/Hz	230/1ph/50	230/1ph/50	230/1ph/50
Product size (w x d x h)	mm	1010 x 326 x 770	1160 x 326 x 770	1495 x 326 x 770
Weight	kg	56.5	65.0	75.5

# WALL-MOUNTED/FLOOR-STANDING SWIMMING POOL DEHUMIDIFIERS

## CDP 40-50-70



### Dimensions

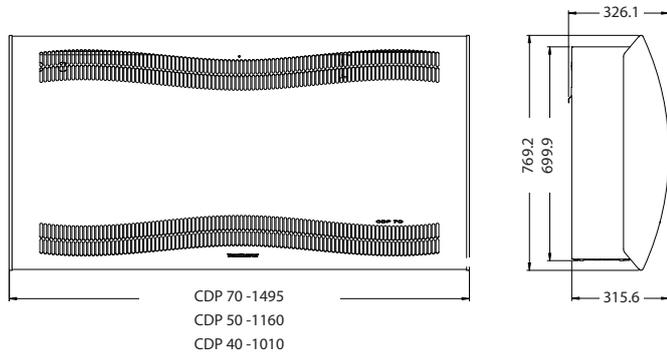

### Drain outlet position

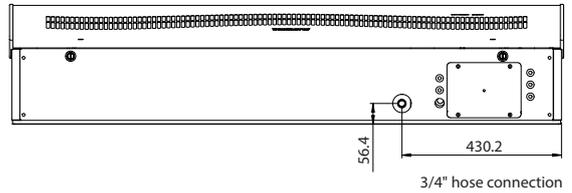

### Recommended installation

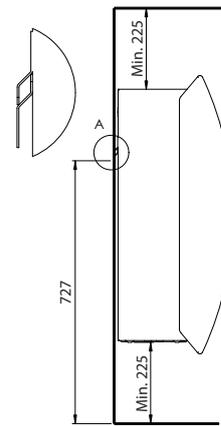

### Floor mounting kit

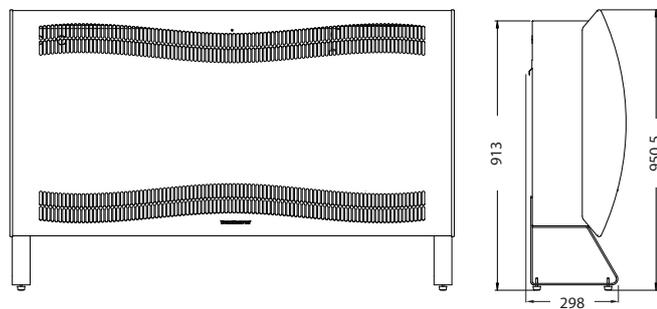

### Performance data

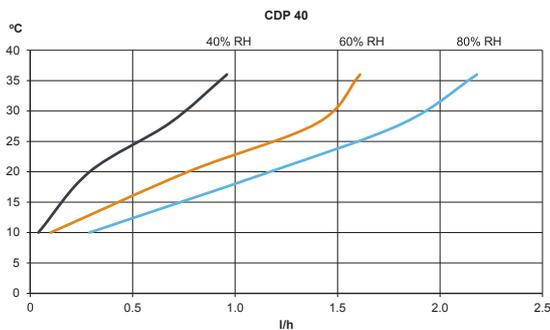

Specific energy consumption (SEC):  
0.47 kWh/l at 28°C & 60% RH

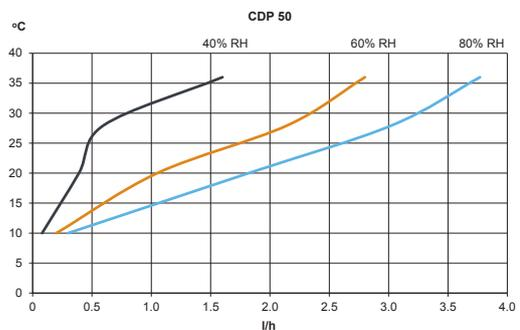

Specific energy consumption (SEC):  
0.48 kWh/l at 28°C & 60% RH

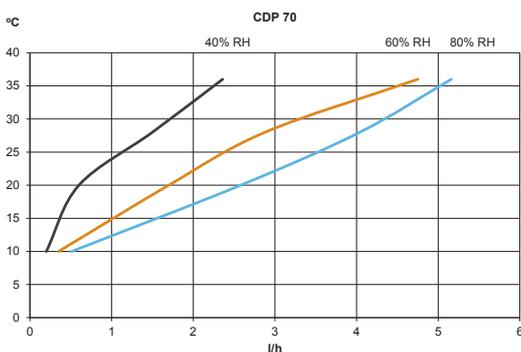

Specific energy consumption (SEC):  
0.43 kWh/l at 28°C & 60% RH

# WALL-MOUNTED SWIMMING POOL DEHUMIDIFIERS

## CDP 40T-50T-70T



**CDP 40T**

The CDP 40T-50T-70T condensation dehumidifiers have been designed for through-the-wall mounting in your swimming pool plant room. Designed as highly durable units, the dehumidifiers come with intuitive remote control and monitoring options for easy operation. Combined with very efficient fans and compressors this secures efficient operation and significant energy savings.

The range is also available in wall-mounted or floor-standing versions.



- Low sound level
- Low energy consumption
- Evaporator and condenser coils are epoxy coated
- Metal parts are powder coated before assembly
- Optional remote control
- Integrated control of heating and humidity (ON/OFF)
- BMS Communication (Modbus)
- Direct connection of 230 V

### Optional accessories



**Wireless remote control DRC1 - 093455**



**Water heating coils - 094333, 094334, 094335**



**Control valve for water heating coil - 094340**

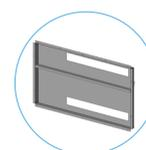

**Duct lead-in adapter - 094801, 094802, 094804**

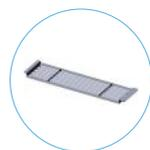

**Electric heating coils - 094336, 094337, 094338**



**Exhaust fans - 094339**

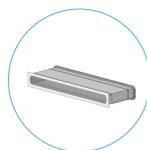

**Through-wall duct kit with filter, extension kit and alu grill - 094271, 094243, 093508**



**External RH/t sensor - 051710**

Specifications	Units	CDP 40T	CDP 50T	CDP 70T
Operating temperature range	°C	10-36	10-36	10-36
Operating humidity range	% RH	40-100	40-100	40-100
Dehumidification @ 28°C/60% RH	l/24h	34	52	69
SEC @ 28°C/60% RH	kWh/l	0.47	0.48	0.43
Air flow	m <sup>3</sup> /h	400	680	900
R407c gas weight/CO <sub>2</sub> equivalent	kg/t	0.7/1.24	0.9/1.60	1.2/2.13
Sound pressure level	dB(A)	43	44	47
Power supply	V/Hz	230/1ph/50	230/1ph/50	230/1ph/50
Product size (w x d x h)	mm	998 x 304 x 700	1148 x 304 x 700	1483 x 304 x 700
Weight	kg	57.5	66.0	77.5

# WALL-MOUNTED SWIMMING POOL DEHUMIDIFIERS

## CDP 40T-50T-70T



### Dimensions

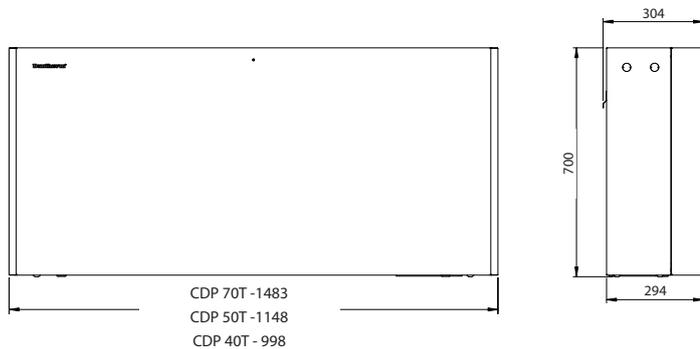

### Drain outlet position

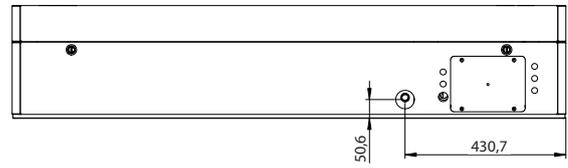

### Duct kits

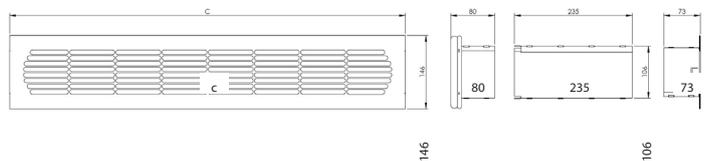
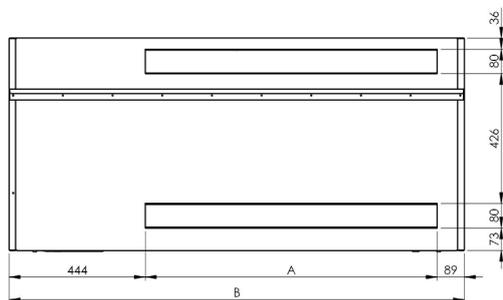

Model	A	B	C	Wall opening
CDP 40T	465	998	642	610 x 110
CDP 50T	616	791	40-100	760 x 110
CDP 70T	950	1483	1126	1095 x 110

All measurements are in mm

### Performance data

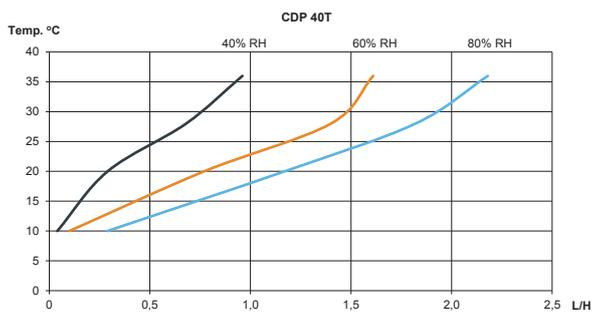

Specific energy consumption (SEC):  
0.47 kWh/l at 28°C & 60% RH

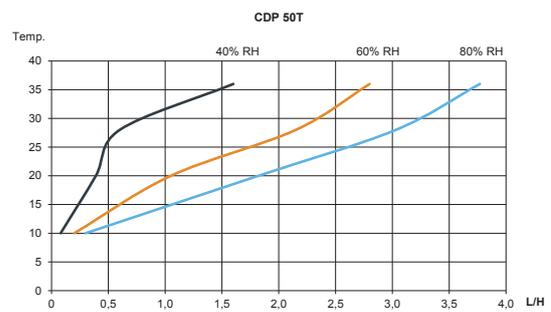

Specific energy consumption (SEC):  
0.48 kWh/l at 28°C & 60% RH

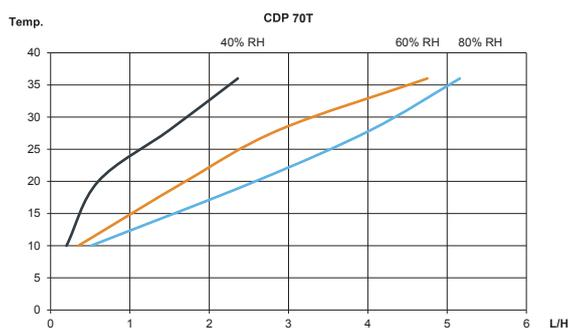

Specific energy consumption (SEC):  
0.43 kWh/l at 28°C & 60% RH

# HIGH CAPACITY DUCTED SWIMMING POOL DEHUMIDIFIERS

## CDP 75-125-165



**CDP 75**

The CDP 75-125-165 condensation dehumidifiers have been designed for ducted installation in your swimming pool plant room. Ideal for hotel pools, private pools and therapy pools, this dehumidifier range is renowned for its build quality and energy efficiency.



- Hot-galvanized, powder painted and double-skinned canbinet with 50mm insulation
- Corrosion-protected evaporator and condenser coils
- The condensate outlet is located on the air inlet side
- The outlet stub can be connected to a water hose
- Air inlet through a filter placed in a removable frame
- Dry air outlet positioned either horizontally (through the side) or vertically (through the top) of the unit
- Moveable inspection access
- Fresh air (15%) inlet possible through fresh air duct
- Optional water-cooled condenser on request
- Rotary/reciprocating compressor
- Radial fan

### Optional accessories



**Room hygrostat - 516301**



**Duct hygrostat - 516310**



**Room thermostat - 513321**

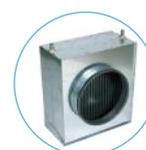

**Water heating coil - 570027, 570028, 570029**



**Shock-absorbing floor mounting kit - 175367, 175368, 175369**



**Wall mounting kit - 175381, 175382**



**Defrost sensor - 175401**



**Failure monitoring kit - 019401**

Specifications	Units	CDP 75	CDP 125	CDP 165
Operating temperature range	°C	20-38	20-38	20-38
Operating humidity range	%	40-100	40-100	40-100
Dehumidification @ 28°C/60% RH	l/24h	74	124	162
Air flow	m <sup>3</sup> /h	1,500	2,500	3,600
Power supply	V/Hz	230/1ph/50	230/1ph/50 + 400/3ph/50	400/3ph/50
Sound level	dB(A)	58	60	63
R407c gas weight/CO <sub>2</sub> equivalent	kg/t	2.1/3.73	5.2/9.22	6.8/12.06
Water-cooled condenser		Optional	Optional	Optional
Product size (w x d x h)	mm	1155 x 725 x 650	1300 x 900 x 850	1400 x 1010 x 975
Weight	kg	130	160	190

# HIGH CAPACITY DUCTED SWIMMING POOL DEHUMIDIFIERS

## CDP 75-125-165



### CDP 75 dimensions

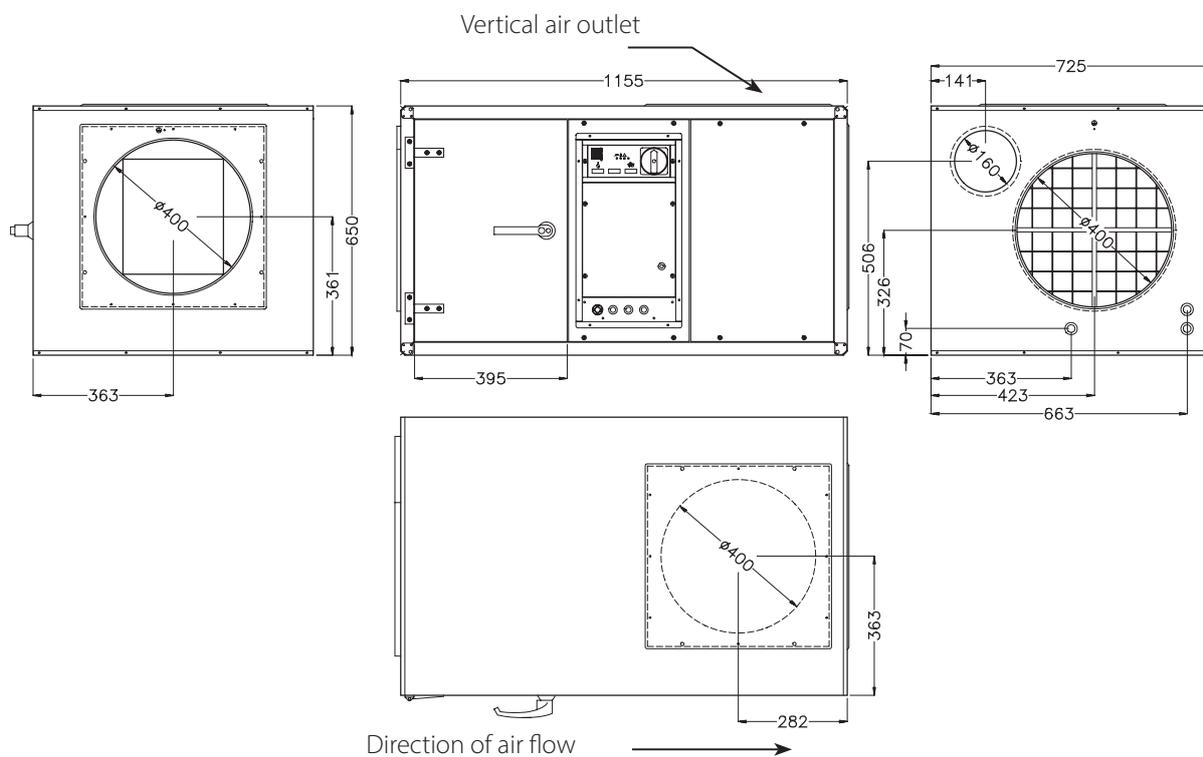

### CDP 125 dimensions

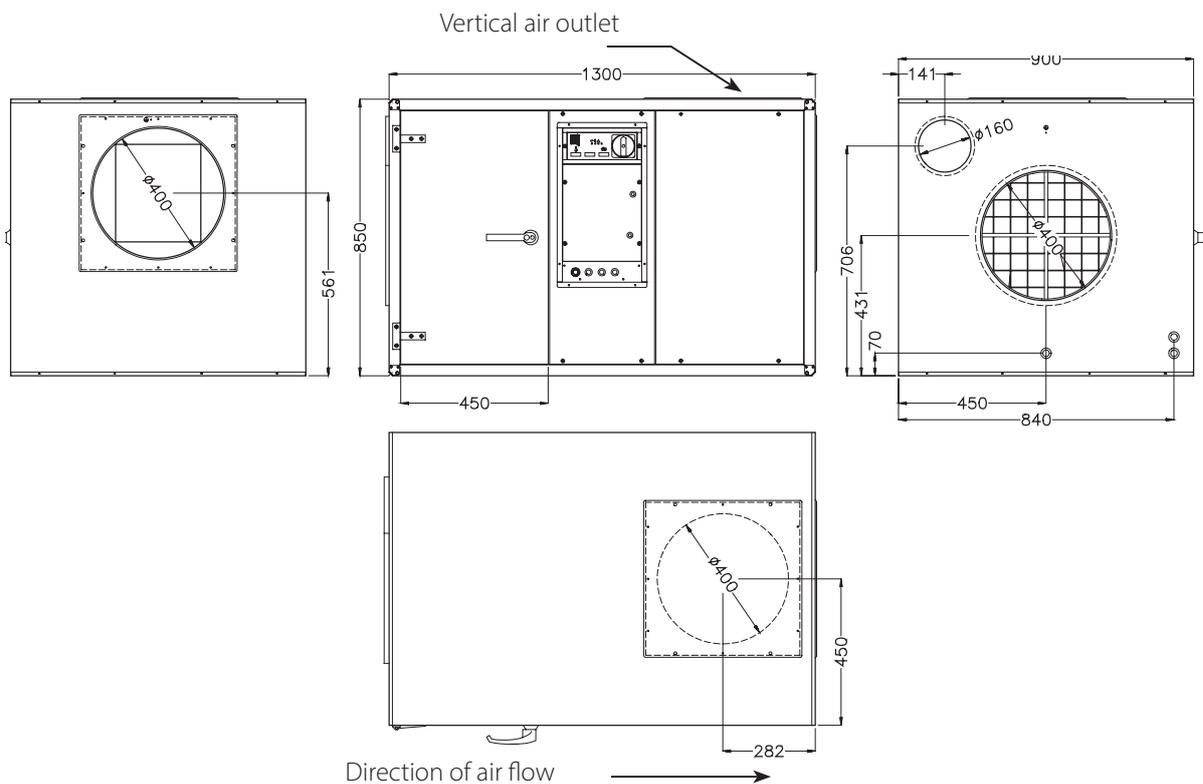

All measurements are in mm

# HIGH CAPACITY DUCTED SWIMMING POOL DEHUMIDIFIERS

## CDP 75-125-165



### Dimensions CDP 165

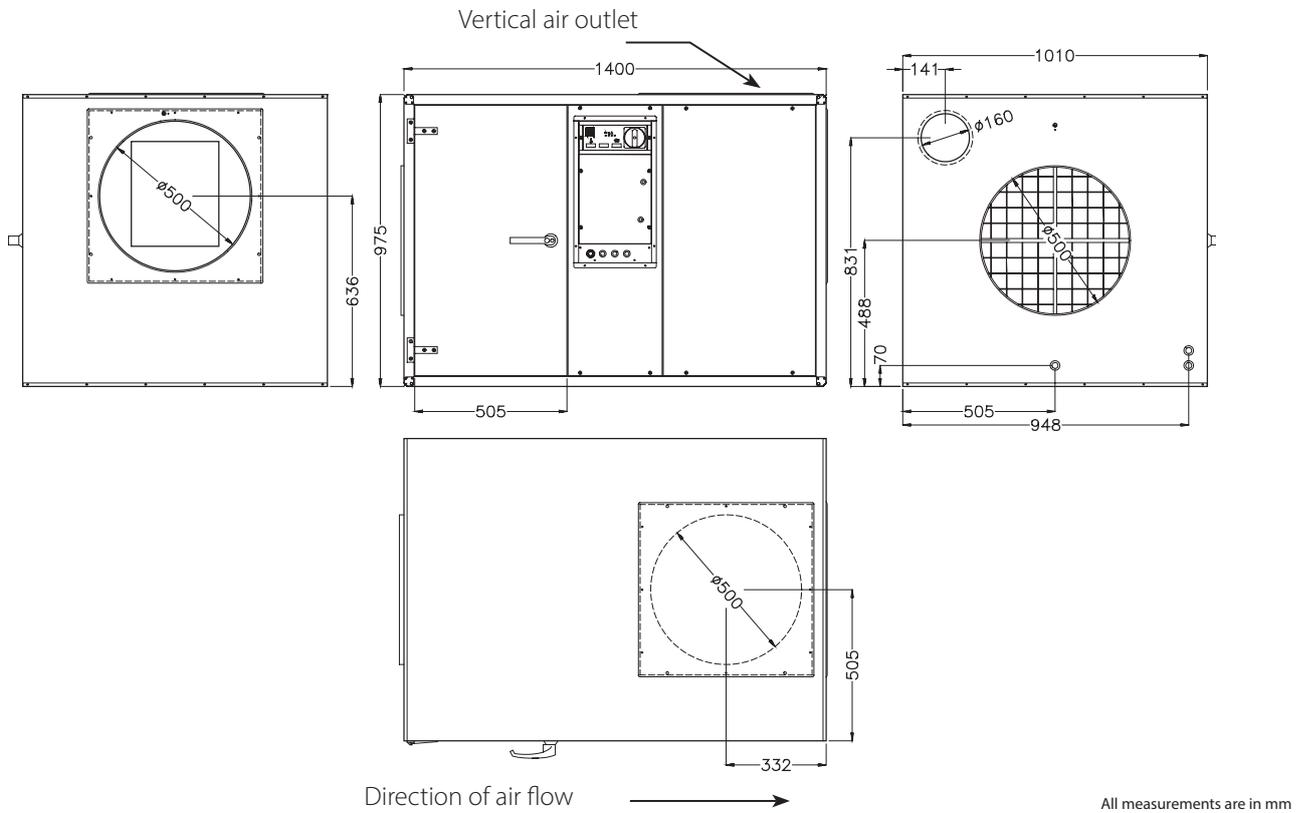

### Performance data

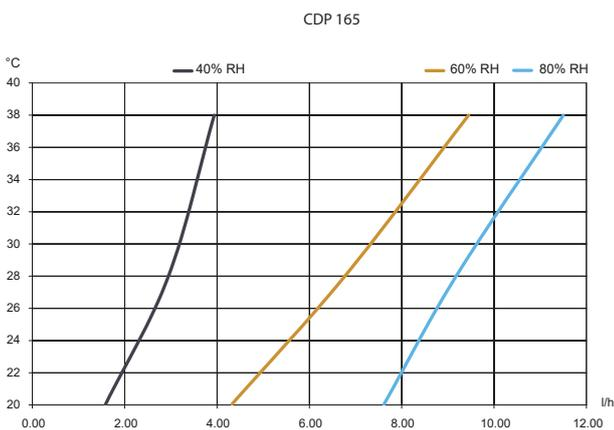
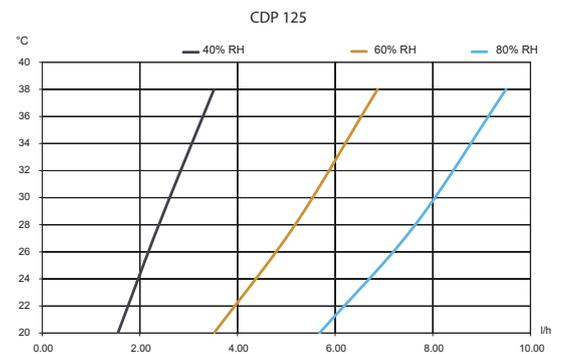
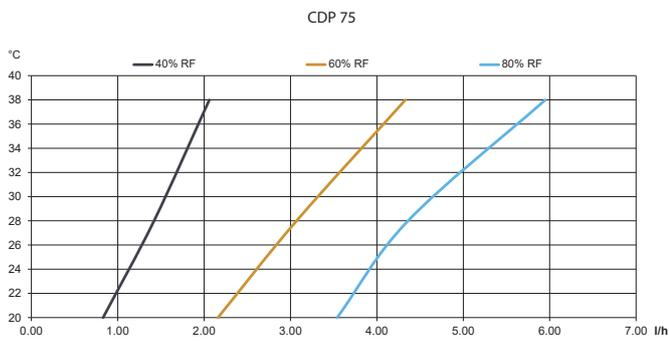

# HIGH CAPACITY DUCTED SWIMMING POOL DEHUMIDIFIERS

## DANX AF



**DANX AF**

The DanX AF is a very effective heat pump dehumidification system, which perfectly controls the humidity and indoor temperature while offering significant running cost reductions. This system is the obvious choice where only limited space is available, or for pools with limited use, for instance hotel pools. Optionally it is also possible to install the unit suspended under the ceiling of the pool room.

For further energy optimization, a water cooled condenser can be integrated into the heat pump. This allows the excess heat to be transferred to the pool or the hot water supply, where it is efficiently reused.



- User-friendly control system that monitors and controls temperature and humidity automatically. The custom-built software runs the unit as efficiently as possible under different conditions.
- BMS communication with either Modbus or BACnet. All internal terminal wiring done from factory.
- Refrigerant circuit with optional built-in water cooled condenser for heating of domestic water and external condenser for hot countries.
- Optional DX or water-cooling coil.
- Highly energy-efficient EC plug fans.
- Highly efficient bag filters with a low pressure drop.
- Fresh air (30%) inlet possible through fresh air duct.
- Load-bearing frame construction module with galvanised, powder-painted sandwich panels with 50mm mineral wool insulation and bottom frame with adjustable feet.
- Specifically designed to withstand the aggressive environments (Corrosion class C4 according to EN/ISO 12944-2), with epoxy coated, coils with aluminium frame, pre-painted fins and with all fasteners, bolts and nuts specially protected.
- Large inspection doors with strong hinges and tongue locks and handles for easy access for service.
- Modular unit for easy and quick installation with all sensors and electrical components already connected. Separate control panel fitted with cables and plugs for quick electrical connection between unit and panel.

Specifications	Units	AF 3/6	AF 5/10	AF 5/10s	AF 7/14	AF 7/14s	AF 12/24	AF 12/24s
Operating temperature range	°C	22-36	22-36	22-36	22-36	22-36	22-36	22-36
Operating humidity	%	50-80	50-80	50-80	50-80	50-80	50-80	50-80
Dehumidification @ 28°C/60% RH	l/h	13	20	25	33	39	52	62
Air flow	m <sup>3</sup> /h	4,850	7,300	9,500	12,000	14,000	19,000	24,000
External duct pressure	Pa	300	300	300	300	300	300	300
Outdoor air	%	0-30	0-30	0-30	0-30	0-30	0-30	0-30
Power supply	V/Hz	400/3ph/50	400/3ph/50	400/3ph/50	400/3ph/50	400/3ph/50	400/3ph/50	400/3ph/50
R407c gas weight/CO <sub>2</sub> equivalent	kg/t	9/15.97	14/24.84	14/24.84	22/39.03	22/39.03	32/56.77	32/56.77
Max. power consumption	kW	8.6	12.3	16.1	22.1	24.1	31.7	42.8
Height	mm	1115	1115	1115	1195	1195	1485	1485
Width	mm	3380	3380	3380	3850	3850	4125	4125
Depth	mm	880	1400	1400	1900	1900	2200	2200
Weight	kg	575	800	800	1125	1200	1650	1675

# HIGH CAPACITY DUCTED SWIMMING POOL DEHUMIDIFIERS

## DANX AF



### Dimensions

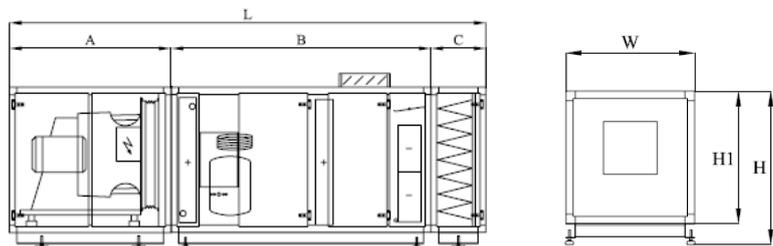

DanX AF	A: mm	B: mm	C: mm	L: mm	W: mm	H: mm	H1: mm	Weight: kg
3/6	985	1920	475	3380	880	1115	915	575
5/10	985	1920	475	3380	1400	1115	915	800
5/10s	985	1920	475	3380	1400	1115	915	800
7/14	1125	2250	475	3850	1900	1195	995	1125
7/14s	1125	2250	475	3850	1900	1195	995	1200
12/24	1400	2250	475	4125	2200	1485	1275	1650
12/24s	1400	2250	475	4125	2200	1485	1275	1675

### Performance data

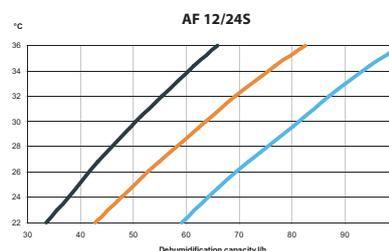
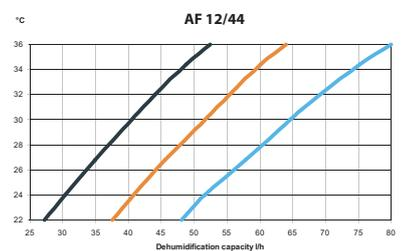
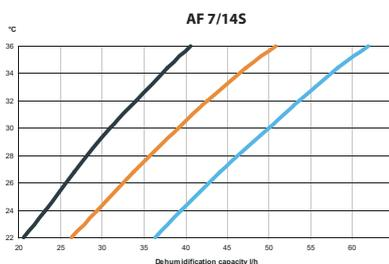
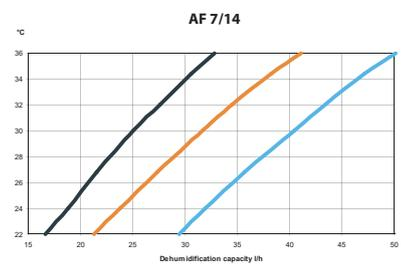
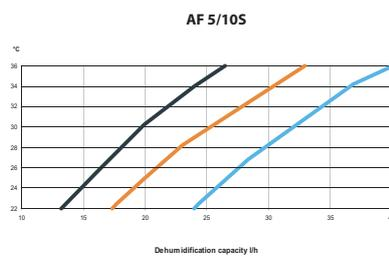
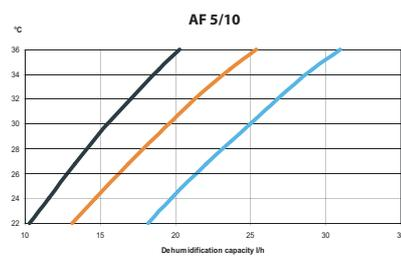
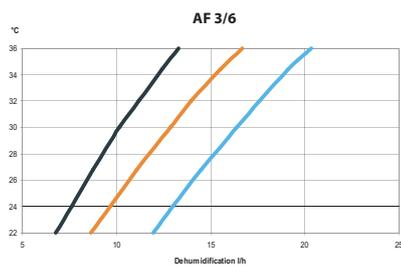



# SWIMMING POOL HEAT PUMPS

Outdoor pools need heating for comfort, but as heat is lost to the atmosphere, new energy must be constantly supplied to keep the pool warm. Heat pumps are recognised as the most sustainable way to dynamically heat swimming pool water, and with a Dantherm heat pump, you ensure this with reduced operating and energy costs

Our residential swimming pool heaters are easy to install on new pools and to retrofit for existing swimming pool systems, with minimal maintenance required.



# HEATING AND COOLING SOLUTIONS FOR: PRIVATE AND DOMESTIC POOLS UP TO 120M<sup>2</sup>

## QUICK GUIDE



HPP-i  
HEAT PUMP



HPP-iw  
HEAT PUMP

### POOL TYPE



OUTDOOR



INDOOR



ABOVE GROUND



### OPERATION



HEATING



COOLING



ALL YEAR HEATING



### APPLICATIONS



PRIVATE POOLS



SPAS



THERAPY & WELLNESS



# INVERTER HEAT PUMPS HPP-i 8-12-16



**HPP-i**

The low energy consumption coupled with high heat production makes the HPP-i heat pump an environmentally friendly way to heat your swimming pool.

Unlike alternative ways of heating pools, the HPP-i heat pump requires no fuel storage tank or high capacity electrical supply. It produces no smell, fumes or CO<sub>2</sub> gases.

HPP-i heat pumps are designed to work all year round when temperatures are above -5°C. Thus, the pool season can be extended for several months.

## Rapid installation, flexible operation

Dantherm HPP-i heat pumps are easy to install and fully self-contained units. When it comes to operation, the HPP-i units offer a quiet, high efficient, reliable, and safe performance.

## Temperature control chart

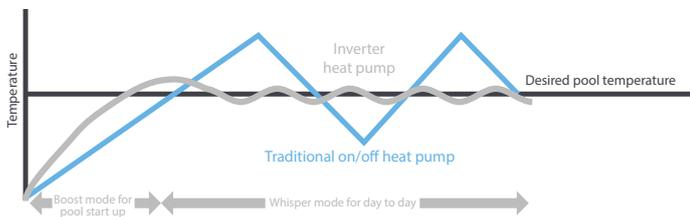

- Inverter heat pump
- Average COP 9.7 = 2 x more efficient than on/off heat pumps
- Eco-friendly refrigerant R32 = 675 GWP, (Global Warming Potential)
- Performance ratings from 9.5 to 25kW
- 9-11 dB(A) sound reduction compared to an equivalent on/off heat pump, with 'Whisper Mode'
- Multifunction operation functions can be set to heating, heat/cool and cooling
- Soft start-up
- Aluminium alloy
- Built-in Wi-Fi module
- Winter cover included

## Controls

The HPP-i heat pump has an integrated controller with a touchscreen user interface.

The basic functions are:

- Function settings for: Heating, Cooling or Heat/Cool
- Parameter adjustment



The PoolTherm App for our Dantherm HPP-i inverter heat pumps is available on Android and iOS. Simply search for 'PoolTherm' in App Store or Google Play and download it today!

## Optional accessories



**Remote LED control kit**

# INVERTER HEAT PUMPS

## HPP-i 8-12-16



### New refrigerant gas

With the introduction F-gas regulations in Europe, our new heat pump will use the low Global Warming Potential (GWP) refrigerant R32.

This refrigerant:

- Has a low GWP (675)
- Has zero ozone depleting potential (ODP)
- Is F-gas phase down compliant
- Requires less refrigerant volume per kW
- Is easier to reuse and recycle



Great value, and environmentally conscious heating option, with energy consumption half that of a traditional on/off heat pump, and 1/10 of that for gas or electric pool heating.

### Heating method efficiency chart

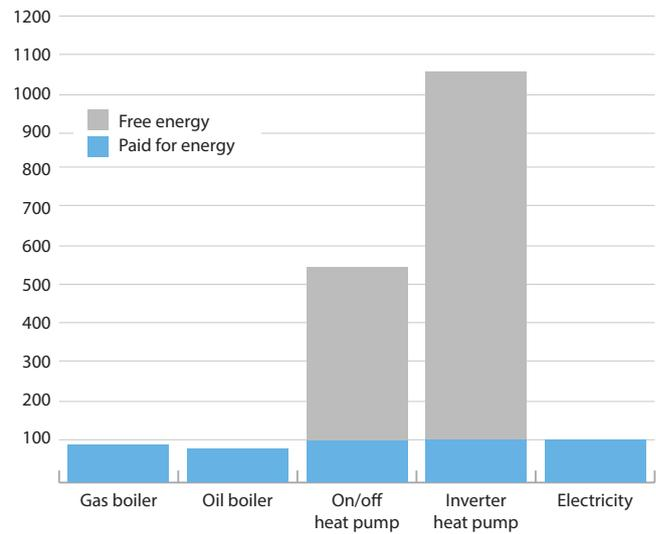

### Dimensions

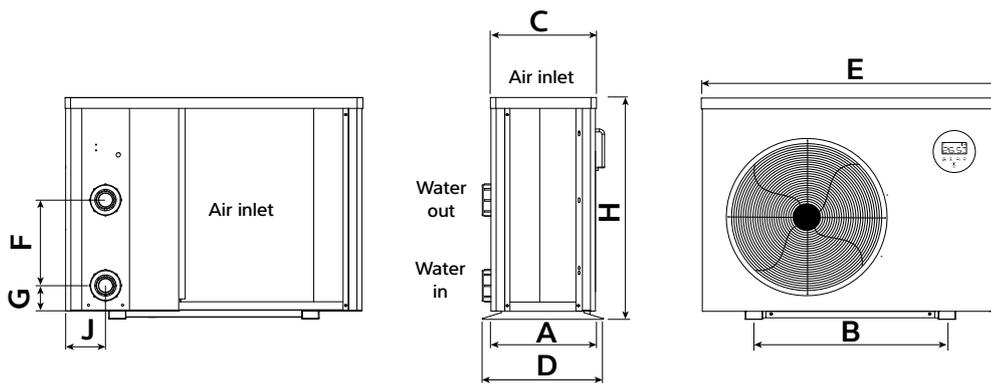

Model	A	B	C	D	E	F	G	H	J
HPP-i 8	334	560	318	359	864	250	74	648	116
HPP-i 12	334	560	318	359	864	290	74	648	116
HPP-i 16	334	590	318	359	954	390	74	748	116

# INVERTER HEAT PUMPS

## HPP-i 8-12-16



Specifications	Units	HPP-i 8	HPP-i 12	HPP-i 16
Air temperature range	°C	-5-43	-5-43	-5-43
Water temperature range	°C	12-40	12-40	12-40
<b>Performance – air 27°C 80% RH, water 27°C</b>				
Heating capacity	kW	9.5	13.0	20.0
COP range		13.2-5.4	13.5-5.6	13.5-5.7
Average COP at 50% speed		8.9	9.7	9.3
<b>Performance – air 15°C 70% RH, water 26°C</b>				
Heating capacity	kW	7.0	9.5	13.5
<b>Performance @ air 5°C 70% RH, water 10°C</b>				
Heating capacity	kW	4.1	5.6	7.9
<b>Performance – air 35°C 80% RH, water 28°C</b>				
Cooling capacity	kW	3.9	5.2	7.4
Power supply	V/Hz	230/1ph/50	230/1ph/50	230/1ph/50
Rated input power	kW	0.3-1.79	0.40-2.38	0.57-3.21
Rated input current	A	1.38-7.58	1.82-10.80	2.60-14.61
Maximum input current	A	9.5	12.5	19.5
Water flow	m <sup>3</sup> /h	3.0-5.0	4.0-6.0	7.0-10.0
Water connection	"/mm	1½/50	1½/50	1½/50
Compressor		Inverter	Inverter	Inverter
Condenser		Titanium	Titanium	Titanium
R32 gas weight/CO <sub>2</sub> equivalent	kg/t	0.6/0.41	0.9/0.61	1.1/0.74
Sound level @ 10m	dB(A)	19.6-31.5	21.9-32.0	24.3-36.1
Sound level @ 1m	dB(A)	39.6-51.5	41.9-52.0	44.3-56.1
Product size (w x d x h)	mm	864 x 359 x 648	864 x 359 x 648	954 x 359 x 748
Weight	kg	47	49	68

# INVERTER HEAT PUMPS

## HPP-iw 12-16-22-28



**HPP-iw**

The low energy consumption coupled with high heat production makes the HPP-iw heat pump an environmentally friendly way to heat your swimming pool.

Unlike alternative ways of heating pools, the HPP-iw heat pump requires no fuel storage tank or high capacity electrical supply. It produces no smell, fumes or CO<sub>2</sub> gases.

HPP-iw heat pumps are designed to work all year round when temperatures are above -10°C. Thus, the pool season can be extended for several months.

### Rapid installation, flexible operation

Dantherm HPP-iw heat pumps are easy to install and fully self-contained units. When it comes to operation, the HPP-iw units offer a quiet, high efficient, reliable, and safe performance.

### Temperature control chart

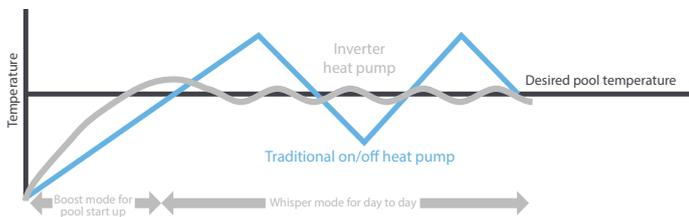

- Inverter heat pump
- Average COP 10.3 = 2 x more efficient than on/off heat pumps
- Eco-friendly refrigerant R32 = 675 GWP, (Global Warming Potential)
- Increased range of performance ratings from 15 to 36kW
- 9-11 dB(A) sound reduction compared to an equivalent on/off heat pump, with 'Whisper Mode'
- Multifunction operation functions can be set to heating, heat/cool and cooling
- Soft start-up
- Aluminium alloy
- Built-in Wi-Fi module
- Winter cover included

### Benefits

- All year heating for outdoor and indoor pools
- Can operate down to -10°C ambient air temperature
- High heating performance at lower temperatures – ideal for quick pool heat up at the start of the season
- Pool heating at altitude
- Higher cooling capacity
- Most efficient models – highest COP



The PoolTherm App for our Dantherm HPP-i inverter heat pumps is available on Android and iOS. Simply search for 'PoolTherm' in App Store or Google Play and download it today!

### Optional accessories



**Remote LED control kit**

# INVERTER HEAT PUMPS

## HPP-iw 12-16-22-28



### New refrigerant gas

With the introduction F-gas regulations in Europe, our new heat pump will use the low Global Warming Potential (GWP) refrigerant R32.

This refrigerant:

- Has a low GWP (675)
- Has zero ozone depleting potential (ODP)
- Is F-gas phase down compliant
- Requires less refrigerant volume per kW
- Is easier to reuse and recycle



Great value, and environmentally conscious heating option, with energy consumption half that of a traditional on/off heat pump, and 1/10 of that for gas or electric pool heating.

### Heating method efficiency chart

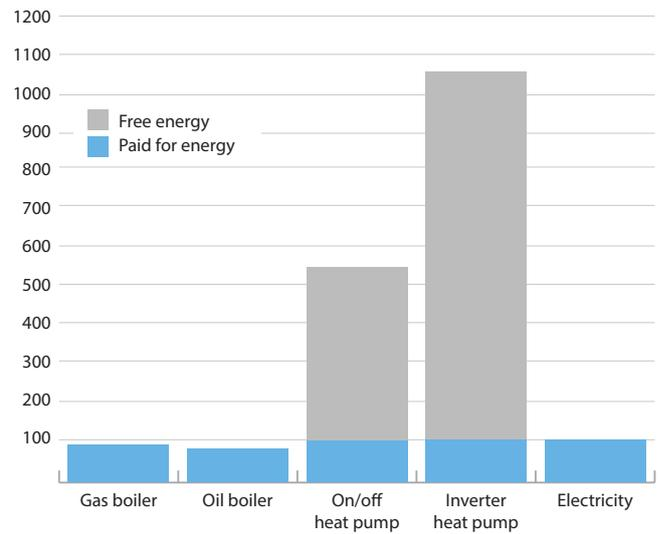

### Dimensions

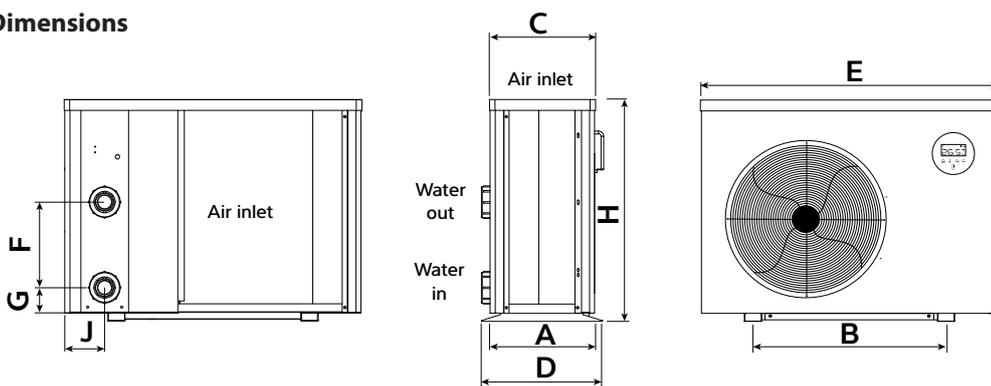

Model	A	B	C	D	E	F	G	H	J
HPP-iw 12	334	590	318	359	954	340	74	648	107
HPP-iw16	404	590	388	429	954	460	74	755	107
HPP-iw 22	404	720	388	429	1084	620	74	948	107
HPP-iw 28	514	790	498	539	1154	650	74	948	128

# INVERTER HEAT PUMPS

## HPP-iw 12-16-22-28



Specifications	Units	HPP-iw 12	HPP-iw 16	HPP-iw 16	HPP-iw 22	HPP-iw 28
Air temperature range	°C	-10-43	-10-43	-10-43	-10-43	-10-43
Water temperature range	°C	12-40	12-40	12-40	12-40	12-40
<b>Performance – air 27°C 80% RH, water 27°C</b>						
Heating capacity	kW	15.0	21.0	21.0	27.5	36.0
COP range		15.0-6.6	14.8-6.4	14.8-6.4	15.0-6.5	14.8-6.0
Average COP at 50% speed		10.6	10.3	10.3	10.3	10.2
<b>Performance – air 15°C 70% RH, water 26°C</b>						
Heating capacity	kW	10.5	14.5	14.5	18.0	23.9
<b>Performance – air 5°C 70% RH, water 10°C</b>						
Heating capacity	kW	7.5	9.6	9.6	11.9	16.0
<b>Performance – air -10°C 70% RH, water 23°C</b>						
Heating capacity	kW	4.6	5.9	5.9	7.3	8.8
<b>Performance – air 35°C 80% RH, water 28°C</b>						
Cooling capacity	kW	6.7	9.5	9.5	11.9	16.0
Power supply	V/Hz	230/1ph/50	230/1ph/50	400/3ph/50	400/3ph/50	400/3ph/50
Rated input power	kW	0.27-2.28	0.41-3.15	0.41-3.15	0.48-3.91	0.64-5.20
Maximum input current	A	13.5	17.0	5.8	9.5	0.92-7.53
Water flow	m <sup>3</sup> /h	5.0-7.0	8.0-10.0	8.0-10.0	10.0-12.0	12.0-18.0
Water connection	"/mm	1½/50	1½/50	1½/50	1½/50	1½/50
Compressor		Inverter	Inverter	Inverter	Inverter	Inverter
Condenser		Titanium	Titanium	Titanium	Titanium	Titanium
R32 gas weight/CO <sub>2</sub> equivalent	kg/t	0.9/0.61	1.2/0.81	1.2/0.81	2/1.35	2.7/1.82
Sound level @ 10m	dB(A)	20.8-24.5	20.4-33.7	20.4-33.7	23.0-34.4	22.1-34.2
Product size (w x d x h)	mm	954 x 359 x 648	954 x 429 x 755	954 x 429 x 755	1084 x 429 x 948	1154 x 539 x 948
Weight	kg	52	68	68	93	120

# SWIMMING POOL AIR HANDLING UNITS

High levels of relative humidity can be extremely damaging to a pool environment, but with a carefully designed ventilation solution, humidity is kept at a comfortable level.

A swimming pool air handling unit must carry out its primary task of dehumidifying the pool space air, be designed and constructed to withstand the pool air environment, and provide a continuously modulated quantity of heated or cooled fresh air for the comfort of all who use it. We can advise on the most effective domestic or commercial pool ventilation products from our selection of heat pump and fresh air technologies.

# ENVIRONMENTAL CONTROL SOLUTIONS FOR: PRIVATE AND COMMERCIAL SWIMMING POOLS

## QUICK GUIDE



DANX 1-2-3 XD



DANX XKS



DANX CF



DANX 1-2-3 HP



DANX XWPS/XWPRS

### POOL TYPE



INDOOR



### OPERATION



WITH HEAT RECOVERY



WITH HEAT RECOVERY AND HEAT PUMP



### APPLICATIONS



PRIVATE POOLS



PUBLIC POOLS



HOTELS, SCHOOLS & HEALTH CLUBS



HOLIDAY & WATER PARKS



LEISURE CENTRES



# DANX 1-2-3 XD



**DANX 1/2/3 XD**

## DanX XD with double crossflow heat exchanger

The DanX XD is a very effective ventilation system that uses outdoor air to provide dehumidification using a double heat exchanger that delivers up to a 95% heat recovery. This reduces energy consumption and total operating costs, thus making the unit perfect for managing humidity and temperature in the pool room.

## For both DanX HP and DanX XD

The built-in mixing function takes care not to add any more outdoor air than necessary to provide a comfortable indoor climate. Free cooling is also an option during the summer, when the unit can add up to 100% outdoor air into the pool area through a bypass. The unit's compact, integrated design enables optimal installation in the technical room. Convenient top or side connections ensure easy access to ducts.

## Optional accessories



**Touchscreen**



- Built-in user friendly control system for high-quality demand management. Automatic monitoring and control of pool hall temperature and humidity. The custom-built software runs the unit as efficiently as possible under different conditions.
- Double crossflow heat exchangers with a high efficiency of up to 95% and a low pressure drop.
- Built-in bypass for free cooling in summertime.
- Highly energy-efficient EC plug fans.
- Efficient M5/ePM10 70% and F7/ePM1 55% compact filters with low pressure drop.
- Self-bearing cabinet with hot-dip galvanised, powder-painted sandwich panels with 50mm mineral wool insulation, internal partition walls with 30mm and bottom frame with adjustable feet.
- Designed to withstand the aggressive swimming pool environment (Corrosion class C4 according to EN/ISO 12944-2), with epoxy-coated crossflow heat exchanger, heating coil with aluminium frame, pre-painted fins and epoxy coating to protect all fasteners, bolts, nuts.
- Two large inspection doors with strong hinges and tongue locks and handles for easy access for service.
- All-in-one box solutions for easy and quick installation – all sensors and electrical components pre-connected.
- BMS communication with either Modbus or BACnet.

Specifications	Units	DANX 1 XD	DANX 2 XD	DANX 3 XD
Nominal air volume	m <sup>3</sup> /h	1,000	1,750	2,750
Max. air volume	m <sup>3</sup> /h	1,300	2,100	3,700
Max. external duct pressure*	Pa	350	350	350
Outdoor air volume	%	0-100	0-100	0-100
Dehumidification capacity VDI 2089**	kg/h	7	11	18
Max. total power consumption	kW	1.1	1.2	1.9
Power supply	V/Hz	230/1ph/50	230/1ph/50	230/1ph/50
Product size (w x d x h)	mm	1750 x 515 x 1570	1750 x 780 x 1570	2250 x 890 x 1990
Weight	kg	254	344	465

\* at nominal air volume, \*\* at 30°C/54% indoor

# SWIMMING POOL AIR HANDLING UNITS WITH HEAT RECOVERY DANX 1-2-3 XD



## DanX 1 XD dimensions

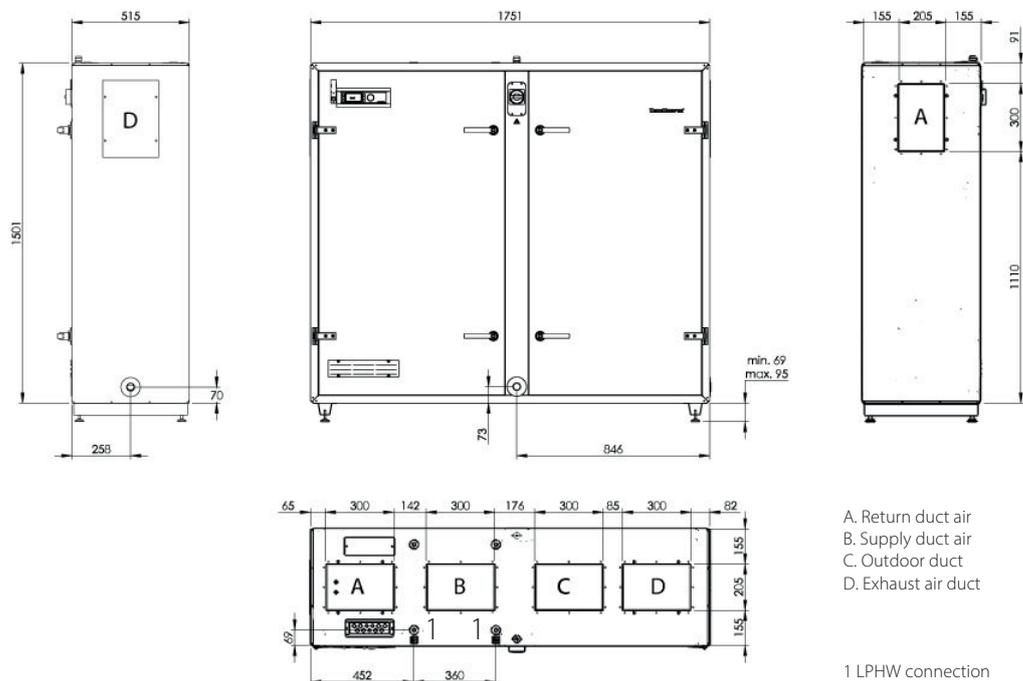

The unit shown in the picture is left hand position.

## DanX 2 XD dimensions

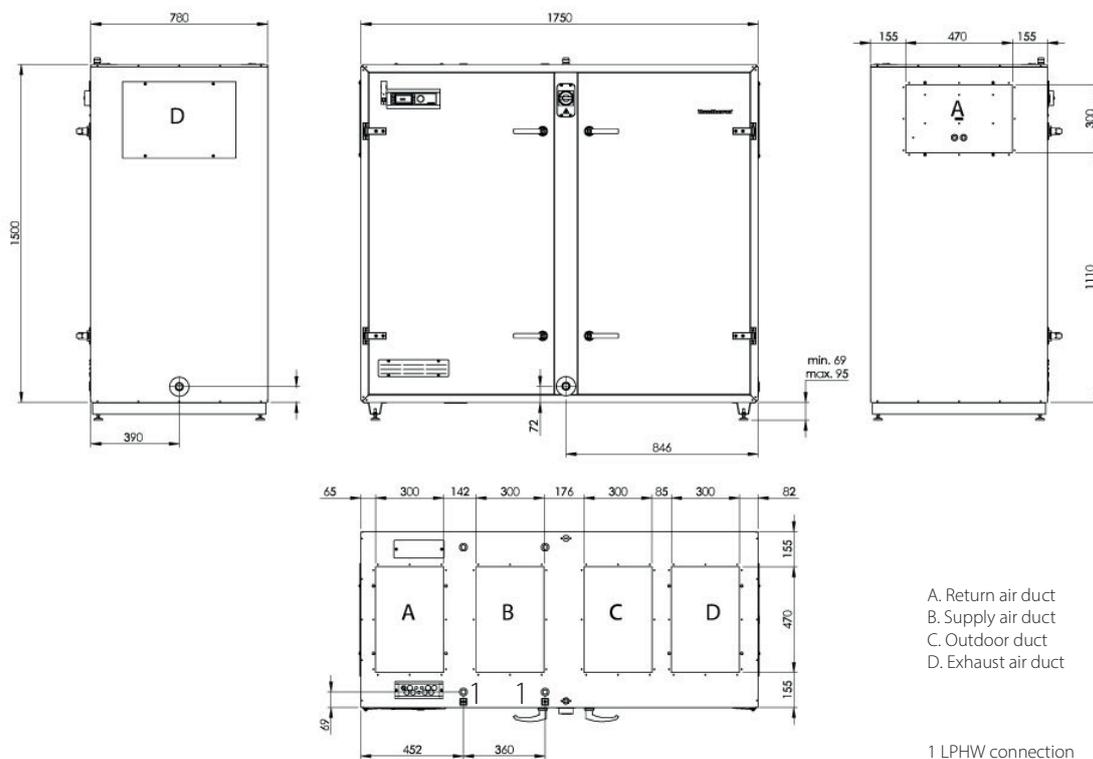

The unit shown in the picture is left hand position.

# SWIMMING POOL AIR HANDLING UNITS WITH HEAT RECOVERY DANX 1-2-3 XD



## DanX 3 XD dimensions

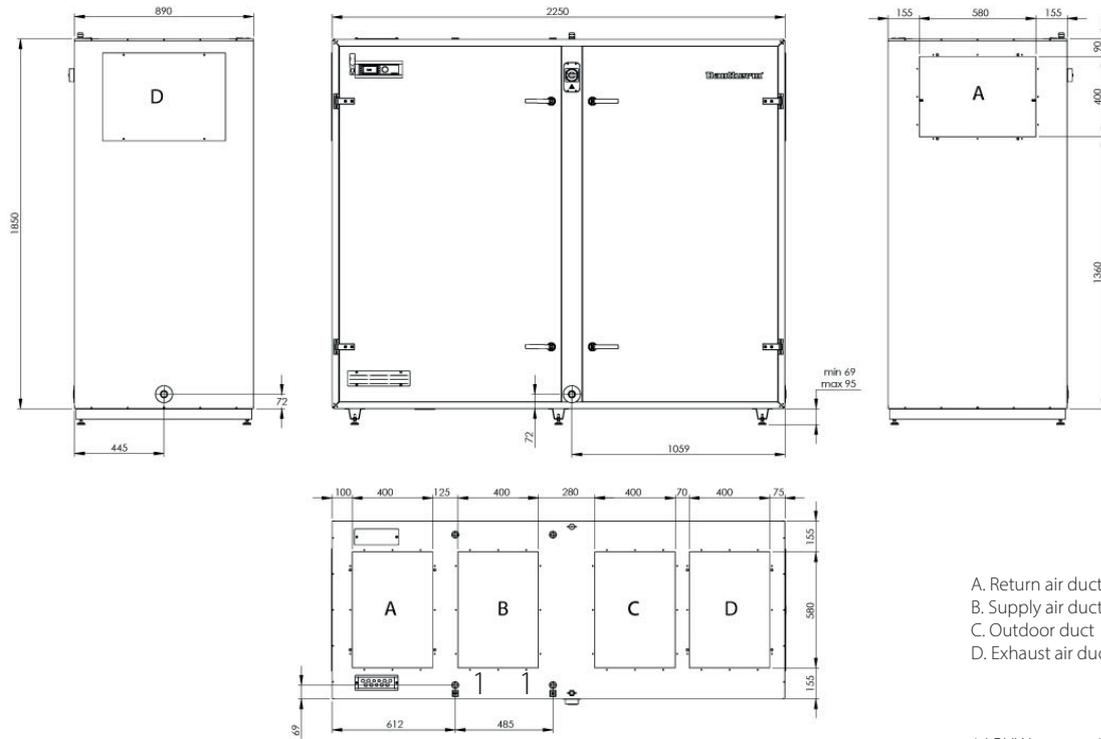

- A. Return air duct
- B. Supply air duct
- C. Outdoor duct
- D. Exhaust air duct

1 LPHW connection

The unit shown in the picture is left hand position.

# SWIMMING POOL AIR HANDLING UNITS WITH HEAT RECOVERY

## DANX XKS



**DANX XKS**

### DanX XKS with cross flow heat exchanger

The DanX XKS is a very effective outdoor air dehumidification system with highly efficient crossflow heat exchanger. This system perfectly controls the humidity and indoor temperature while offering significant running cost reductions due to real energy savings of up to 80%. The integrated mixing function ensures that only the exact quantity of outdoor air needed is supplied – which keeps running costs at a minimum.

Free cooling is also an option during summer, when the unit can add up to 100% outdoor air into the pool area through the integrated bypass.

For countries with high outdoor summer temperatures, the system can be equipped with an additional cooling coil for further dehumidification and air cooling.

Optionally, we offer various fan types, filter qualities and coils to perfectly match to the requirements.



- User-friendly control system for high-quality demand management. Automatic monitoring and control of temperature and humidity of the pool hall.
- Crossflow heat exchanger with a high efficiency of more than 75% and a low pressure drop.
- Built-in bypass for free cooling in the summertime.
- Highly energy-efficient EC plug fans.
- Efficient bag filters in different lengths and qualities with low pressure drops are available.
- Load-bearing frame construction module with hot-dip galvanised, powder-painted sandwich panels with 50mm mineral wool insulation, internal partition walls with 30mm and bottom frame with adjustable feet.
- Designed to withstand the aggressive swimming pool environment (Corrosion class C4 according to EN/ISO 12944-2), with epoxy-coated crossflow heat exchanger, heating coil with aluminium frame, pre-painted fins and epoxy coating to protect all fasteners, bolts, nuts.
- IP66 damper motors designed for swimming pool use.
- Large inspection doors with strong hinges and tongue locks and handles for easy access for service.
- Modular unit for easy and quick installation with all sensors and electrical components already connected. Separate control panel fitted with cables and plugs for quick electrical connection between unit and panel.
- BMS communication with either Modbus or BACnet.

Specifications	Units	2/4 XKS	3/6 XKS	5/10 XKS	7/14 XKS	9/18 XKS	12/24 XKS	16/32 XKS
Nominal air volume	m <sup>3</sup> /h	3,350	4,500	8,400	12,500	15,500	21,500	25,500
Max. air volume	m <sup>3</sup> /h	4,500	6,000	10,000	14,000	20,000	26,000	32,000
Outdoor air volume	%	0-100	0-100	0-100	0-100	0-100	0-100	0-100
Dehumidification capacity VDI 2089*	kg/h	22	29	54	81	100	139	165
Max. total power consumption**	kW	2.2	3.0	6.0	11.0	15.0	22.0	60.0
Power supply	V/Hz	400/3ph/50	400/3ph/50	400/3ph/50	400/3ph/50	400/3ph/50	400/3ph/50	400/3ph/50
Height	mm	1600	1960	1960	2120	2250	2760	3010
Width	mm	3101	3572	3572	3712	4080	4270	5100
Depth	mm	880	880	1400	1900	1800	2200	2200
Weight	kg	850	925	1300	1675	1925	2550	3300

\* at 30°C/54% indoor, \*\* at nominal air volume

# DANX XKS



## DanX XKS dimensions

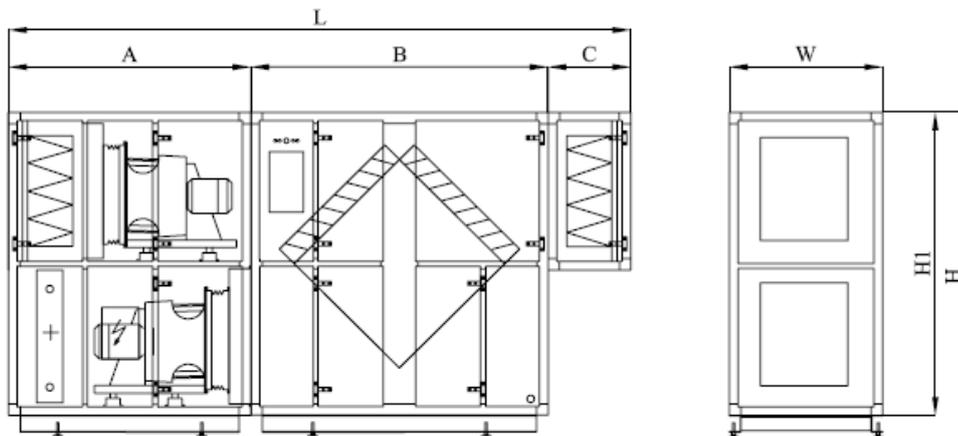

DanX XKS	A mm	B mm	C mm	L mm	W mm	H mm	H1 mm	Weight kg
2/4	1285	1341	475	3101	880	1600	1400	850
3/6	1390	1707	475	3572	880	1960	1760	925
5/10	1390	1707	475	3572	1400	1960	1760	1300
7/14	1530	1707	475	3712	1900	2120	1920	1675
9/18	1685	1920	475	4080	1800	2550	2350	1925

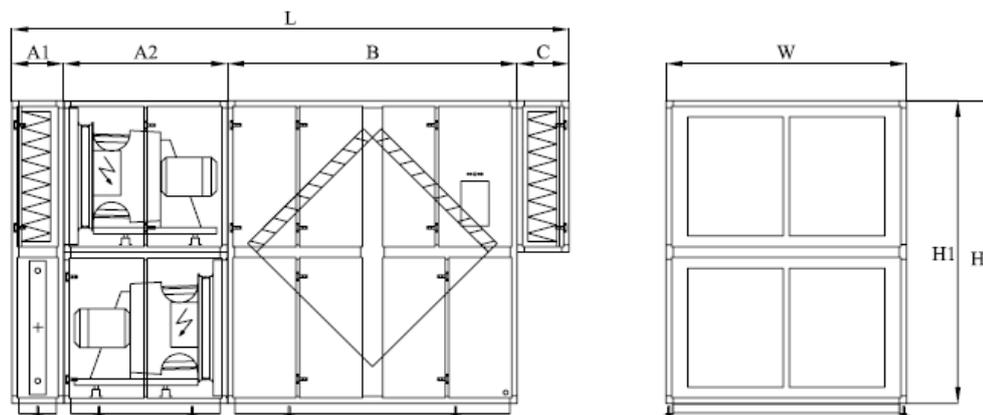

DanX XKS	A mm	A2 mm	B mm	C mm	L mm	W mm	H mm	H1 mm	Weight kg
12/24	475	1400	1920	475	4270	2200	2760	2550	2550
16/32	475	1500	2650	475	5100	2200	3010	2800	3300

# SWIMMING POOL AIR HANDLING UNITS

## DANX CF



**DANX CF**

The DanX CF is a very effective outdoor air dehumidification system with a highly efficient cross flow heat exchanger. This system perfectly controls the humidity and indoor temperature while offering significant running cost reductions due to real energy savings of up to 80%. The integrated mixing function ensures that only the exact quantity of outdoor air needed is supplied. This keeps running costs at a minimum.

Free cooling is also an option during summer, when the unit can add up to 100% outdoor air into the pool area through the integrated by-pass.

For countries with high outdoor summer temperatures the system can be equipped with an additional cooling coil for further dehumidification and air cooling.

A wide range of fan types, filter qualities and coils are available on request, enabling you to create the perfect solution for your requirements.



- User-friendly control system for high-quality demand management. Automatic monitoring and control of temperature and humidity of the pool hall
- Double counter-flow heat exchangers with a high efficiency of more than 90% and a low pressure drop
- Built-in bypass for free cooling in the summertime.
- Highly energy-efficient EC plug fans
- Efficient bag filters in different lengths and qualities with low pressure drops are available
- Load-bearing frame construction module with hot-dip galvanised, powder-painted sandwich panels with 50mm mineral wool insulation, internal partition walls with 30mm and bottom frame with adjustable feet
- Designed to withstand the aggressive swimming pool environment (corrosion class C4 according to EN/ISO 12944-2), with epoxy-coated crossflow heat exchanger, heating coil with aluminium frame, pre-painted fins and epoxy coating to protect all fasteners, bolts, nuts
- Large inspection doors with strong hinges and tongue locks and handles for easy access for service
- Modular unit for easy and quick installation – all sensors and electrical components pre-connected.
- BMS communication with either Modbus or BACnet

## SWIMMING POOL AIR HANDLING UNITS

# DANX CF

Specifications	Units	DANX CF 3/5	DANX CF 4/7	DANX CF 6/9	DANX CF 8/12
Nominal air volume	m <sup>3</sup> /h	3,100	4,400	6,300	8,000
Max air volume	m <sup>3</sup> /h	4,500	6,500	9,000	11,500
Outdoor air volume	%	0-100	0-100	0-100	0-100
Dehumidification capacity VDI 2089*	kg/h	20	29	41	52
Power supply	V/Hz	400/3ph/50	400/3ph/50	400/3ph/50	400/3ph/50
Height	mm	1700	1700	2300	2300
Width	mm	3790	3790	4490	4490
Depth	mm	880	1185	1185	1473
Weight	kg	800	960	1335	1530

Specifications	Units	DANX CF 10/14	DANX CF 12/17	DANX CF 16/23	DANX CF 19/28	DANX CF 22/32
Nominal air volume	m <sup>3</sup> /h	9,800	11,600	16,000	19,000	22,000
Max air volume	m <sup>3</sup> /h	14,000	17,000	23,000	28,000	32,000
Outdoor air volume	%	0-100	0-100	0-100	0-100	0-100
Dehumidification capacity VDI 2089*	kg/h	63	75	104	123	142
Power supply	V/Hz	400/3ph/50	400/3ph/50	400/3ph/50	400/3ph/50	400/3ph/50
Height	mm	2300	2300	3000	3600	3600
Width	mm	4490	4490	4760	4760	4760
Depth	mm	1778	2066	1964	2066	2370
Weight	kg	1730	1950	2365	2685	2755

\* at 30°C/54% indoor

# SWIMMING POOL AIR HANDLING UNITS

## DANX CF

### DanX CF dimensions

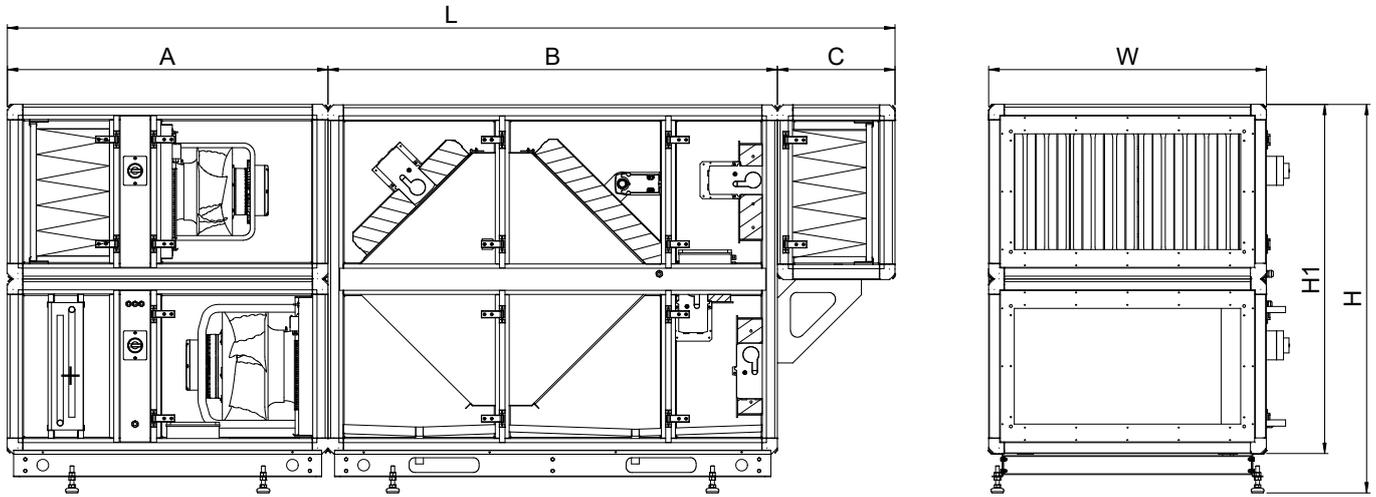

DanX CF	A mm	B mm	C mm	L mm	W mm	H1 mm	H mm	Weight kg
3/5	1370	1920	500	3790	880	1500	1700	800
4/7	1370	1920	500	3790	1185	1500	1700	960
6/9	1490	2500	500	4490	1185	2100	2300	1335
8/12	1490	2500	500	4490	1473	2100	2300	1530
10/14	1490	2500	500	4490	1778	2100	2300	1730
12/17	1490	2500	500	4490	2066	2100	2300	1950
16/23	1490	2770	500	4760	1964	2800	3000	2365
19/28	2770	500	4760	2066	3400	3600	2685	2685
22/32	2770	500	4760	2370	3400	3600	2755	2755

# SWIMMING POOL AIR HANDLING UNITS WITH HEAT RECOVERY AND HEAT PUMP DANX 1-2-3 HP



**DANX 1/2/3 HP**

## DanX HP with double cross flow heat exchanger and heat pump

The DanX HP combines the strengths of a heat pump system with a system that dehumidifies using outdoor air. The combined heat pump and highly effective double cross flow heat exchanger precisely regulate both humidity and temperatures in the pool room.

In addition to heat recovery exceeding 100% the heat pump optimises dehumidification, so that the proportion of outdoor air never exceeds what is necessary to ensure comfort. For further energy optimization, a water-cooled condenser can be integrated into the heat pump. This allows the excess heat to be transferred to the pool or the hot water supply, where it is reused.

## Optional accessories



**Touchscreen**



- Built-in heat pump with rotary compressor and high COP. Optional built-in water cooled condenser for heating of the pool or domestic water.
- Built-in user friendly control system for high-quality demand management. Automatic monitoring and control of pool hall temperature and humidity.
- Double crossflow heat exchangers with a high efficiency of more than 85% and a low pressure drop.
- Built-in bypass for free cooling in the summertime.
- Highly energy-efficient EC plug fans.
- Efficient M5/ePM10 70% and F7/ePM1 55% compact filters with low pressure drop.
- Self-bearing cabinet with hot-dip galvanised, powder-painted sandwich panels with 50mm mineral wool insulation, internal partition walls with 30mm and bottom frame with adjustable feet.
- Designed to withstand the aggressive swimming pool environment (Corrosion class C4 according to EN/ISO 12944-2), with epoxy-coated crossflow heat exchanger, coils with aluminium frame, pre-painted fins and epoxy coating to protect all fasteners, bolts and nuts.
- Two large inspection doors with strong hinges and tongue locks and handles for easy access for service.
- All-in-one box solutions for easy and quick installation with all sensors and electrical components already connected.
- BMS communication with either Modbus or BACnet.

Specifications	Units	DANX 1 HP	DANX 2 HP	DANX 3 HP
Nominal air volume	m <sup>3</sup> /h	1,000	1,750	2,750
Max. air volume	m <sup>3</sup> /h	1,300	2,100	3,500
Max. external duct pressure*	Pa	350	350	350
Outdoor air volume	%	0-100	0-100	0-100
Dehumidification capacity recirculation**	kg/h	1.7	4.2	6.9
Dehumidification capacity VDI 2089**	kg/h	7	11	18
Power consumption compressor**	kW	0.6	1.2	1.9
Max. total power consumption	kW	1.7	2.9	4.6
Power supply	V/Hz	230/1ph/50	400/2ph/50	400/2ph/50
Product size (w x d x h)	mm	1750 x 515 x 1570	1750 x 780 x 1570	2250 x 890 x 1990
Weight	kg	279	379	500

\* at nominal air volume, \*\* at 30°C/54% indoor

# SWIMMING POOL AIR HANDLING UNITS WITH HEAT RECOVERY AND HEAT PUMP DANX 1-2-3 HP



## DanX 1 HP dimensions

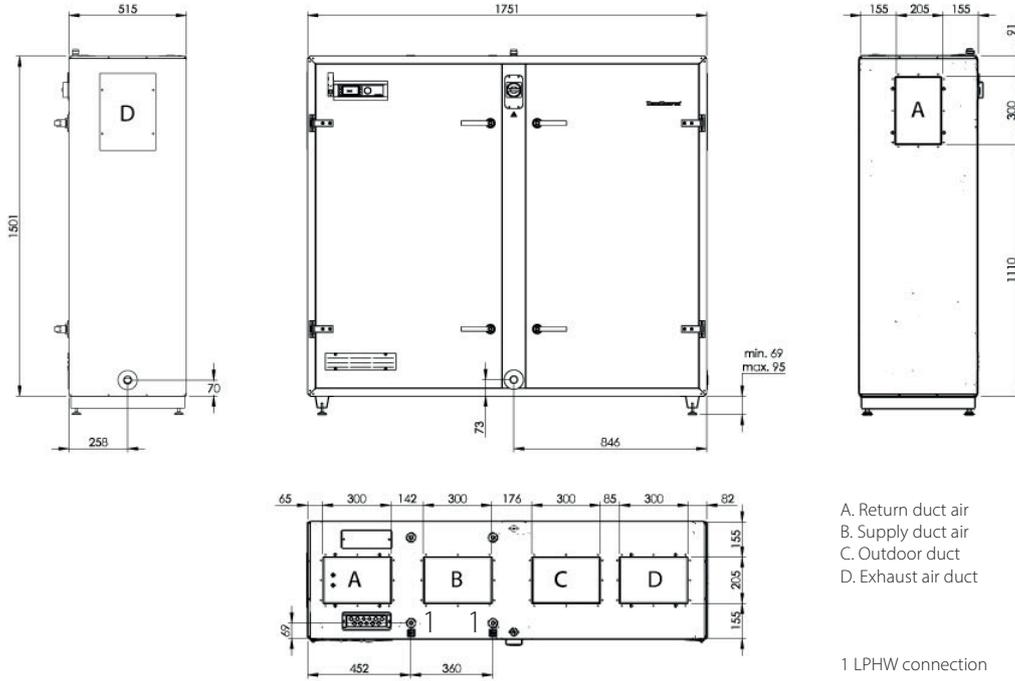

- A. Return duct air
- B. Supply duct air
- C. Outdoor duct
- D. Exhaust air duct

1 LPHW connection

The unit shown in the picture is left hand position.

## DanX 2 HP dimensions

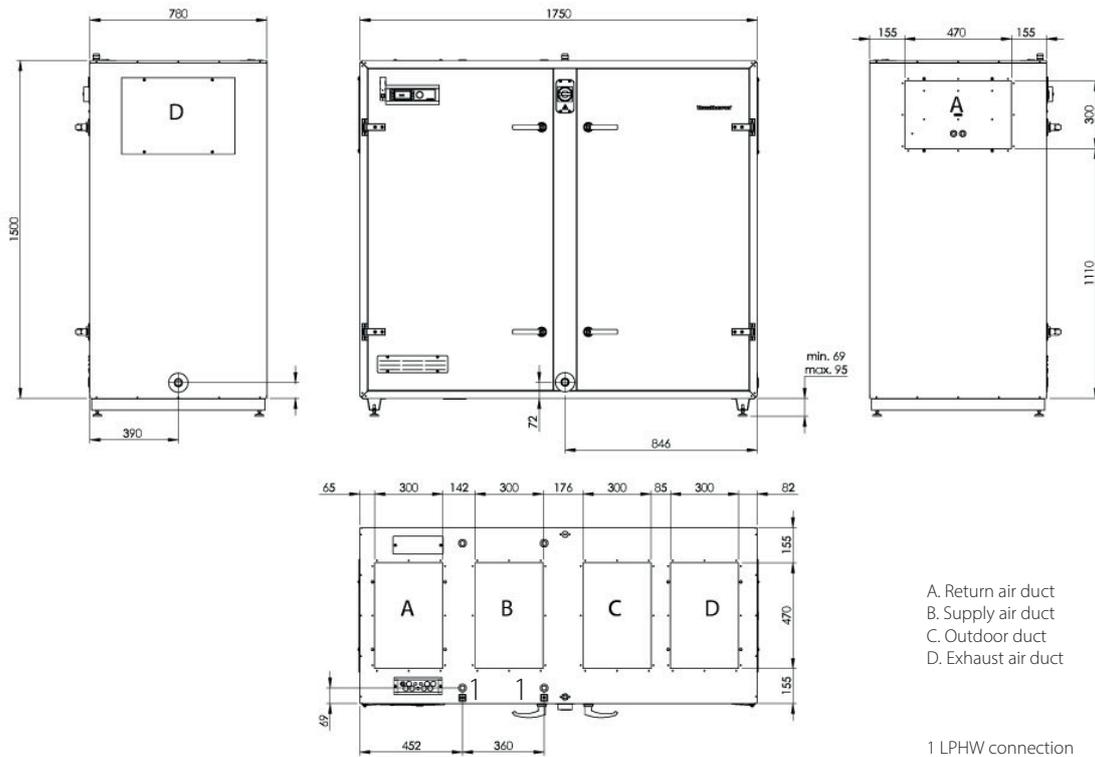

- A. Return air duct
- B. Supply air duct
- C. Outdoor duct
- D. Exhaust air duct

1 LPHW connection

The unit shown in the picture is left hand position.

# SWIMMING POOL AIR HANDLING UNITS WITH HEAT RECOVERY AND HEAT PUMP DANX 1-2-3 HP



## DanX 3 HP XD dimensions

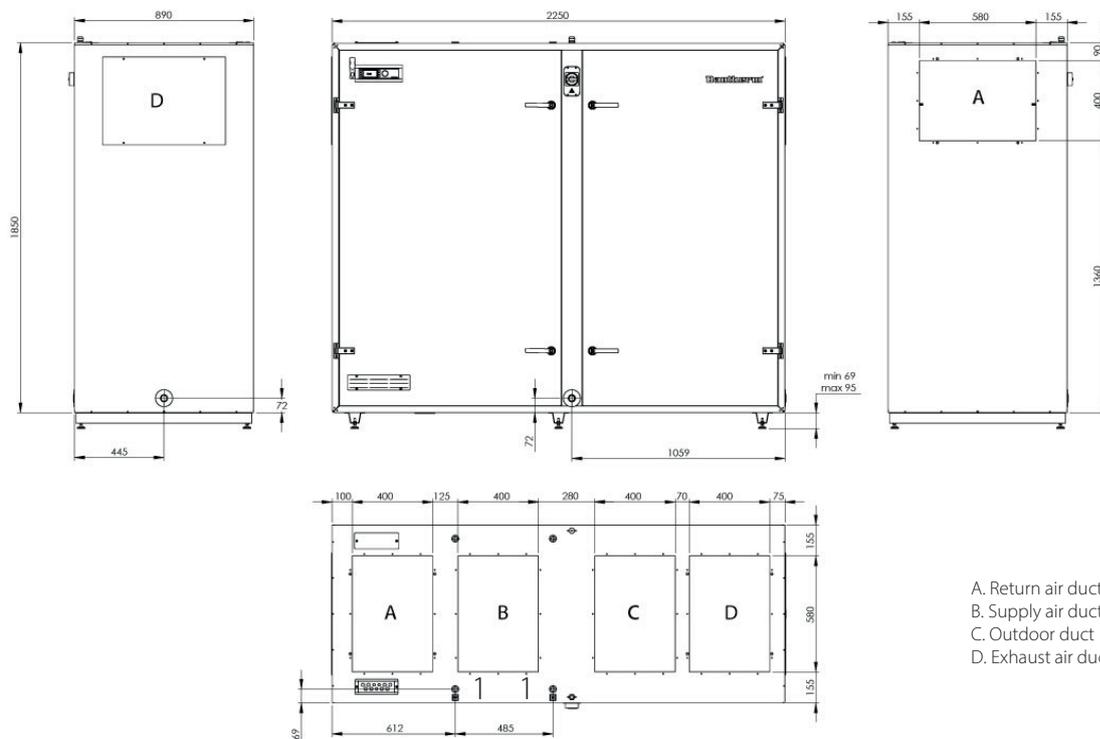

- A. Return air duct
- B. Supply air duct
- C. Outdoor duct
- D. Exhaust air duct

1 LPHW connection

The unit shown in the picture is left hand position.

# SWIMMING POOL AIR HANDLING UNITS WITH HEAT RECOVERY AND HEAT PUMP DANX XWPS



**DANX XWPS**

## DanX XWPS with heat pump and cross flow heat exchanger

The DanX XWPS combines the best of heat pumps and outside air dehumidification systems. The combination of heat pump and a highly efficient crossflow heat exchanger with an efficiency that exceeds 75% enables you to take full control of both humidity and indoor temperature.

Significant running cost reductions due to energy savings may exceed 100%.

The integrated mixing function ensures that only the exact quantity of outdoor air required to sustain comfortable conditions is supplied.



- Built-in heat pump with scroll compressor and high COP. Optional built-in water-cooled condenser for heating of pool or domestic water.
- User-friendly control system for high-quality demand management. Automatic monitoring and control of pool hall temperature and humidity.
- Very efficient crossflow heat exchanger.
- Built-in by pass for free cooling in the summertime.
- Highly energy-efficient EC plug fans.
- Efficient bag filters in different lengths and qualities with low pressure drops are available.
- Load-bearing frame construction module with hot-dip galvanised, powder-painted sandwich panels with 50mm mineral wool insulation, internal partition walls with 30mm and bottom frame with adjustable feet.
- Designed to withstand the aggressive swimming pool environment (Corrosion class C4 according to EN/ISO 12944-2), with epoxy-coated crossflow heat exchanger, coils with aluminium frame, pre-painted fins and epoxy coating to protect all fasteners, bolts and nuts.
- IP66 damper motors designed for pool environments.
- Large inspection doors with strong hinges and tongue locks and handles for easy access for service.
- Modular unit for easy and quick installation with all sensors and electrical components already connected.
- BMS communication with either Modbus or BACnet.

Specifications	Units	2/4 XWPS	3/6 XWPS	5/10 XWPS	7/14 XWPS	9/18 XWPS	12/24 XWPS	16/32 XWPS
Nominal air volume	m <sup>3</sup> /h	3,350	4,500	8,400	12,500	15,500	21,500	25,500
Max. air volume	m <sup>3</sup> /h	4,500	6,000	10,000	14,000	20,000	26,000	32,000
Outdoor air volume	%	0-100	0-100	0-100	0-100	0-100	0-100	0-100
Dehumidification capacity recirculation*	kg/h	9	16	24	31	40	64	71
Dehumidification capacity VDI 2089*	kg/h	22	29	54	81	100	139	165
Max. power consumption compressor	kW	4.4	5.7	8.8	12.0	16.0	24.0	30.0
Max. total power consumption**	kW	7.4	10.1	16.8	23.0	31.0	46.0	60.0
Power supply	V/Hz	400/3ph/50	400/3ph/50	400/3ph/50	400/3ph/50	400/3ph/50	400/3ph/50	400/3ph/50
R407c gas weight/CO <sub>2</sub> equivalent	kg/t	9/15.97	11/19.51	13/23.06	15/26.61	20/35.48	25/44.35	30/53.22
Height	mm	1600	1960	1960	2120	2250	2760	3010
Width	mm	3665	4135	4135	4275	4660	4950	5868
Depth	mm	880	880	1400	1900	1800	2200	2200
Weight	kg	1150	1300	1800	2300	2700	3650	4600

\* at 30°C/54% indoor, \*\* at nominal air volume

# SWIMMING POOL AIR HANDLING UNITS WITH HEAT RECOVERY AND HEAT PUMP DANX XWPS



## DanX XWPS dimensions

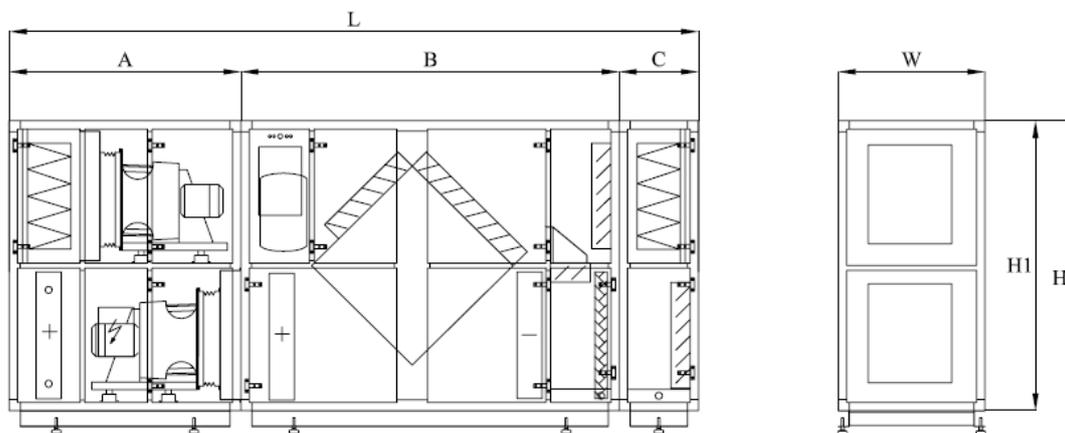

DanX XWPS	A mm	B mm	C mm	L mm	W mm	H mm	H1 mm	Weight kg
2/4	1285	1905	475	3665	880	1600	1400	1150
3/6	1390	2270	475	4135	880	1960	1760	1300
5/10	1390	2270	475	4135	1400	1960	1760	1800
7/14	1530	2270	475	4275	1900	2120	1920	2300
9/18	1685	2500	475	4660	1800	2550	2350	2700

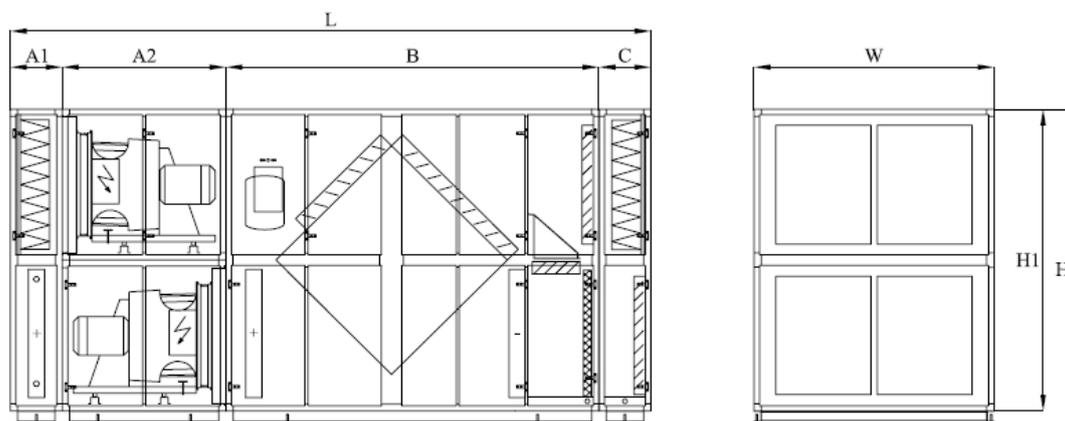

DanX XWPS	A1 mm	A2 mm	B mm	C mm	L mm	W mm	H mm	H1 mm	Weight kg
12/24	475	1400	2600	475	4950	2200	2760	2550	3650
16/32	475	1500	3418	475	5868	2200	3010	2800	4600

# SWIMMING POOL AIR HANDLING UNITS WITH HEAT RECOVERY AND HEAT PUMP DANX XWPRS



**DANX XWPRS**



- Built-in heat pump with scroll compressor and high COP. Optional built-in water-cooled condenser for heating of pool or domestic water.
- User-friendly control system for high-quality demand management. Automatic monitoring and control of pool hall temperature and humidity.
- Crossflow heat exchanger with a +75% efficiency.
- Built-in bypass for free cooling in the summertime.
- Reversible heat pump for active summer cooling.
- Highly energy-efficient EC plug fans.
- Efficient bag filters in different lengths and qualities with low pressure drops are available.
- Load bearing frame construction module with hot-dip galvanised, powder-painted sandwich panels with 50mm mineral wool insulation, internal partition walls with 30mm and bottom frame with adjustable feet.
- Designed to withstand the aggressive swimming pool environment (Corrosion class C4 according to EN/ISO 12944-2), with epoxy-coated crossflow heat exchanger, coils with aluminium frame, pre-painted fins and epoxy coating to protect all fasteners, bolts and nuts.
- IP66 damper motors designed for swimming pool use.
- Large inspection doors with strong hinges and tongue locks and handles for easy access for service.
- Modular unit for easy and quick installation with all sensors and electrical components already connected.
- BMS communication with either Modbus or BACnet.

## DanX XWPRS with heat pump and cross flow heat exchanger

The DanX XWPRS combines the advantages of heat pumps and outside air dehumidification systems. The combination of the heat pump and a highly efficient crossflow heat exchanger gives you full control of the humidity as well as the indoor temperature. The reversible heat pump offers the possibility of active cooling in the summer.

The potential running cost reductions are significant and may well exceed 100%.

The integrated mixing function ensures that only the exact quantity of outdoor air required to sustain comfortable conditions is supplied.

Specifications	Units	2/4 XWPRS	3/6 XWPRS	5/10 XWPRS	7/14 XWPRS	9/18 XWPRS	12/24 XWPRS	16/32 XWPRS
Nominal air volume	m <sup>3</sup> /h	3,350	4,500	8,400	12,500	15,500	21,500	25,500
Max. air volume	m <sup>3</sup> /h	4,500	6,000	10,000	14,000	20,000	26,000	32,000
Outdoor air volume	%	0-100	0-100	0-100	0-100	0-100	0-100	0-100
Dehumidification capacity recirculation*	kg/h	9	16	24	33	43	68	81
Dehumidification capacity VDI 2089*	kg/h	22	29	54	81	100	139	165
Max. power consumption compressor	kW	4.4	5.7	8.8	12.0	16.0	24.0	30.0
Max. total power consumption**	kW	7.4	10.1	16.8	23.0	31.0	46.0	60.0
Power supply	V/Hz	400/3ph/50	400/3ph/50	400/3ph/50	400/3ph/50	400/3ph/50	400/3ph/50	400/3ph/50
R407c gas weight/CO <sub>2</sub> equivalent	kg/t	9/15.97	11/19.51	13/23.06	15/26.61	20/35.48	25/44.35	30/53.22
Height	mm	1600	1960	1960	2120	2250	2760	3010
Width	mm	3665	4135	4135	4275	4660	4950	5868
Depth	mm	880	880	1400	1900	1800	2200	2200
Weight	kg	1150	1300	1800	2300	2700	3650	4600

\* at 30°C/54% indoor, \*\* at nominal air volume

# SWIMMING POOL AIR HANDLING UNITS WITH HEAT RECOVERY AND HEAT PUMP DANX XWPRS



## DanX XWPRS dimensions

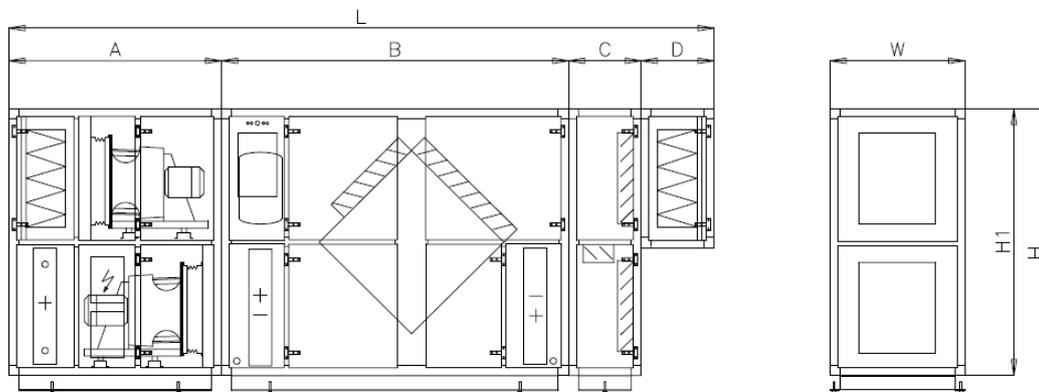

DanX XWPRS	A mm	B mm	C mm	D mm	L mm	W mm	H mm	H1 mm	Weight kg
2/4	1285	2270	475	475	4140	880	1600	1400	1215
3/6	1390	2270	475	475	4610	880	1960	1760	1420
5/10	1390	2270	475	475	4610	1400	1960	1760	1925
7/14	1530	2270	475	475	4750	1900	2120	1920	2600
9/18	1685	2500	600	475	5260	1800	2550	2350	2910

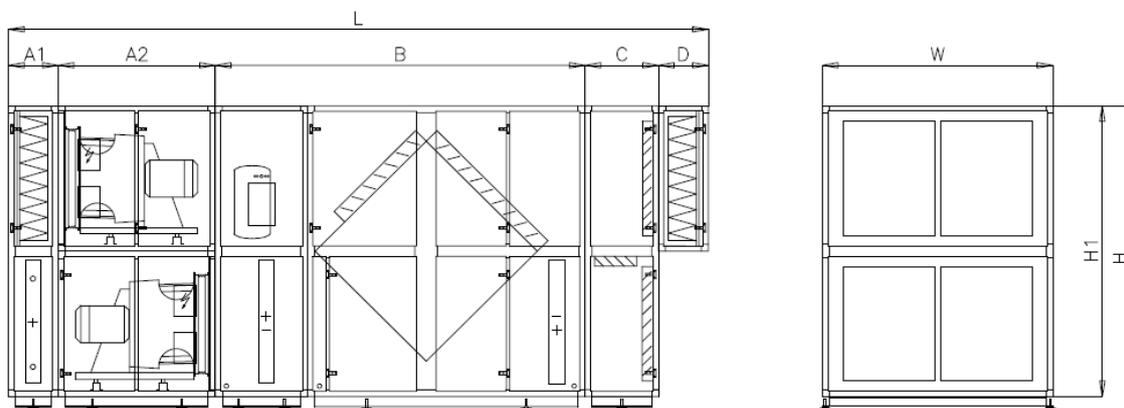

DanX XWPRS	A mm	B mm	C mm	D mm	L mm	W mm	H mm	H1 mm	Weight kg
12/24	475	1400	2600	600	475	2200	2760	2550	3990
16/32	475	1500	3530	700	475	2200	3010	2800	4940



# CONDENSE DEHUMIDIFIERS

Dantherm's range of powerful dehumidifiers provides the ideal means of preserving and protecting your valuables from humidity damage. They are suited for humidity control in warehouses, museums, churches, archives and waterworks.

# DEHUMIDIFICATION SOLUTIONS FOR: BUILDINGS, STORAGE, PRESERVATION, FOOD & BEVERAGE

## QUICK GUIDE



CDF 10



CD 15

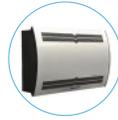

CDF 40-50-70



CDP 75-125-165



DANX AF

### INSTALLATION



WALL-MOUNTED



FLOOR-STANDING



DUCTED



### APPLICATIONS



WATERWORKS



DRYING ROOMS



PRESERVATION STORAGE  
& WAREHOUSING



MUSEUMS, ARCHIVES  
& GALLERIES



GARAGES &  
CAR STORAGE



DRY STORAGE,  
INDUSTRIAL  
PROCESS DRYING



# WALL-MOUNTED DEHUMIDIFIERS

## CDF 10



**CDF 10**

The CDF 10 dehumidifier is ideal for protecting furnishings and equipment stored at low temperatures. Being fully automatic with electronic control and a built-in, adjustable hygostat, the unit has a clear display that indicates the current status of operation.

Defrosting is incorporated in the electronic control. The CDF 10 dehumidifier is operational at temperatures down to 3°C, where the electronic control switches off the dehumidifier.



- Built into a strong and robust powder-coated and hot-galvanised sheet metal cabinet
- Evaporator and condenser coils are epoxy-coated for high corrosion resistance
- The condensate outlet is located at the bottom of the CDF dehumidifier. The outlet stub can be connected to a water hose
- Easy accessible washable air filters from front cover
- Reciprocating compressor
- Axial fan
- Electronic control and user-friendly display panel
- Active, demand-controlled defrosting
- Available in white and grey



**CDF 10**  
with water tank

### Optional accessories



**Room hygostat - 516301**



**White tank - 351615**  
**Grey tank - 351616**

Specifications	Units	CDF 10
Operating temperature range	°C	3-30
Operating humidity range	% RH	40-100
Dehumidification @ 30°C/60% RH	l/24h	7.5
Air flow	m <sup>3</sup> /h	220
Power supply	V/Hz	230/1ph/50
Max. power consumption	kW	0.3
Sound pressure level @ 1m	dB(A)	46
R134a gas weight/CO <sub>2</sub> equivalent	kg/t	0.19/0.27
Water container capacity	l	5.5
Product size (w x d x h)	mm	535 x 240 x 600
Weight	kg	28

# WALL-MOUNTED DEHUMIDIFIERS

## CDF 10



### CDF 10 dimensions

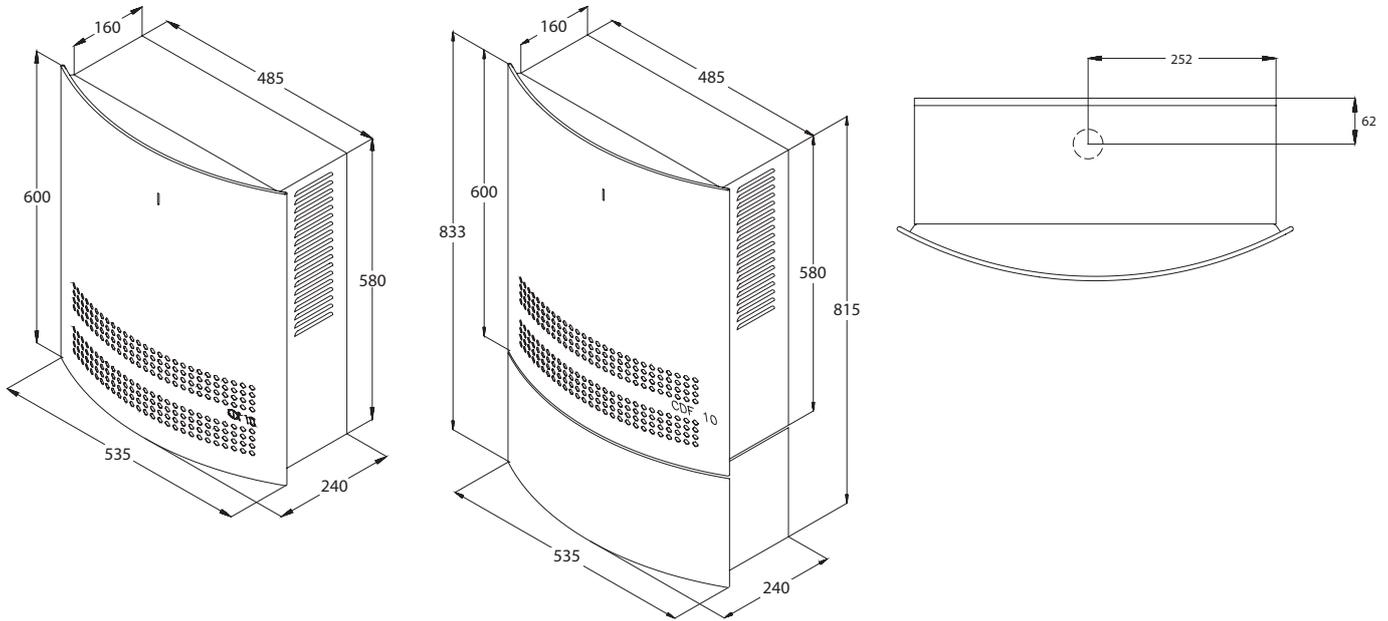

### Performance data

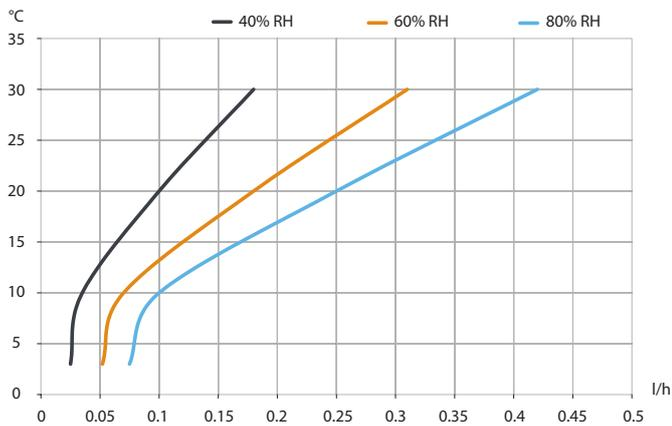

### Electronic control

The CDF 10 has a built-in hygrostat and is fully automatic with electronic control. The hygrostat is placed behind the front panel and the required relative humidity level can be adjusted by moving the set screw. On delivery the CDF 10 is set at approx. 60% RH.

The CDF 10 is switched on and off by the switch on the side of the unit. A green LED on the front panel lights when the compressor is operating.

If the CDF 10 is used with a water container, it switches off automatically when the water tank is full. A red LED on the front panel lights when the water container needs to be emptied.

### Defrosting

Active, demand-controlled defrosting is incorporated in the electronic control. A sensor on the evaporator coil ensures that the evaporator is only defrosted when required. The evaporator coil is defrosted by means of hot refrigerant bypassing the condenser and being fed through the evaporator.

The CDF 10 is automatically switched off when the temperature is lower than 3°C. It restarts when the room temperature has increased to more than 3°C.

# WALL-MOUNTED DEHUMIDIFIERS

## CD 15



**CD 15**

The CD 15 is compact, lightweight, robust and quiet. Powerful and highly efficient, it constitutes a great and versatile solution for a number of different dehumidification tasks.

Fitted with a bracket for fast and simple wall mounting it is ideally suited for use in water management facilities, car storage, preservation, museums, archives, cellars, spas, domestic use and more.



- Built into a strong and brushed stainless steel cabinet
- Built-in hygrostat
- Operating hour counter
- Easy accessible air filters from front cover
- Reciprocating compressor
- F-gas directive compliant
- Energy efficient axial fan
- Electronic control and user-friendly display panel
- Active, demand-controlled defrosting
- Automatic pump-out with overflow protection
- Wall bracket included
- On-demand hot gas defrost system



**CD 15**  
with automatic pump

### Optional accessories



**Replacement air filter**  
490146



**Condensate drainage hose**  
490100  
12 x 2mm

Specifications	Units	CD 15
Operating temperature range	°C	5-30
Operating humidity range	% RH	40-100
Dehumidification @ 30°C/80% RH	l/24h	15.0
Dehumidification @ 20°C/60% RH	l/24h	8.5
Air flow	m <sup>3</sup> /h	225
Power supply	V/Hz	230/1ph/50
Max. power consumption	kW	0.3
Sound pressure level @ 1m	dB(A)	46
Refrigerant		R1234yf
R1234yf gas weight/CO <sub>2</sub> equivalent	kg/t	0.14/0.0006
Product size (w x d x h)	mm	330 x 280 x 490
Weight	kg	18.5

# WALL-MOUNTED DEHUMIDIFIERS

## CD 15



### CD 15 dimensions

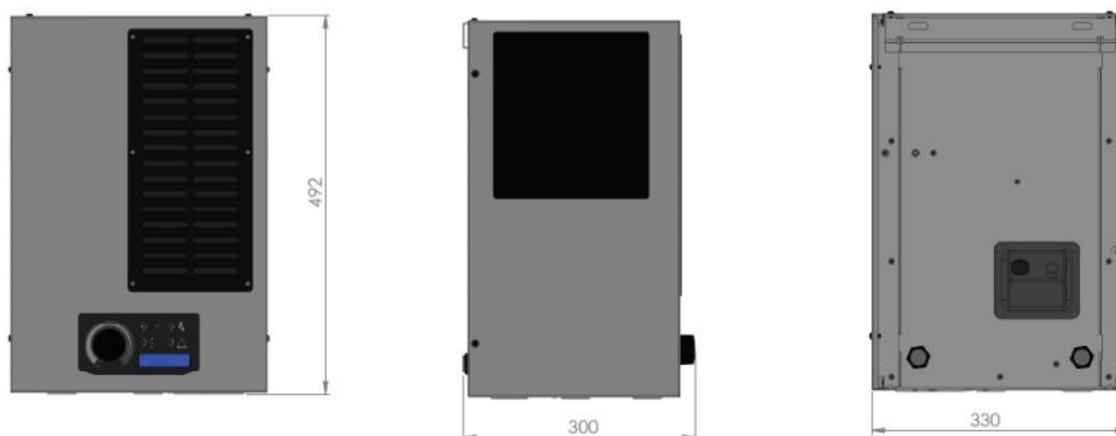

Dimensions above include external fittings  
All measurements are in mm

### Electronic control

The CD 15 is fully automatic with electronic control, avoiding unnecessary operating times and helping to save energy. Controls include:

- LED for "Pump error"
- LED for "Temperature warning"
- LED for Relative humidity OK"

# WALL-MOUNTED/FLOOR-STANDING DEHUMIDIFIERS

## CDF 40-50-70



**CDF 50**

The energy-efficient and quiet CDF range of powerful dehumidifiers is ideal for preserving and protecting your valuables from humidity damage. They are suitable for humidity control in garages, warehouses, museums, churches, archives and waterworks.

### Controls

- Built in electronic hygrostat and thermostat
- Integrated ON/OFF control of humidity and temperature (electric or water heating coils as accessories)
- 230 V for control valve, exhaust fan and pump/boiler
- RS485 for Modbus communication

- Modern design
- Low sound level
- Low energy consumption
- Integrated control of humidity and temperature
- BMS communication (Modbus RTU)
- Built into a strong and robust powder-coated and hot-galvanised sheet metal cabinet
- Evaporator and condenser coils epoxy-coated to maximise corrosion resistance



### Optional accessories



**Wireless remote control DRC1-093455**



**Floor mounting kit - 094332**



**Water heating coils - 094333, 094334, 094335**



**Control valve for water heating coil - 094340**



**Electric heating coils - 094336, 094337, 094338**



**Exhaust fans - 094339**

Specifications	Units	CDF 40	CDF 50	CDF 70
Operating temperature range	°C	3-32	3-32	3-32
Operating humidity range	% RH	40-100	40-100	40-100
Dehumidification @ 30°C/60% RH	l/24h	30	53	55
SEC @ 28°C/60% RH	kWh/l	0.80	0.63	0.58
Air flow	m <sup>3</sup> /h	400	680	900
Power supply	V/Hz	230/1ph/50	230/1ph/50	230/1ph/50
Max. power consumption	kW	0.78	1.37	1.5
Sound pressure level @ 1m	dB(A)	46	47	50
R407c gas weight/CO <sub>2</sub> equivalent		0.7/1.24	0.9/1.60	1/2/2.13
Filter		G3 PPI 15	G3 PPI 15	G3 PPI 15
Condensate drain size (stub)	inch	¾	¾	¾
Product size (w x d x h)	mm	1010 x 326 x 770	1160 x 326 x 770	1495 x 326 x 770
Weight	kg	56.5	65.0	75.5

# WALL-MOUNTED/FLOOR-STANDING DEHUMIDIFIERS

## CDF 40-50-70



### Dimensions

### Recommended installation

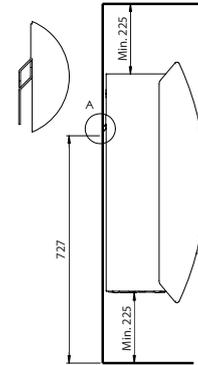
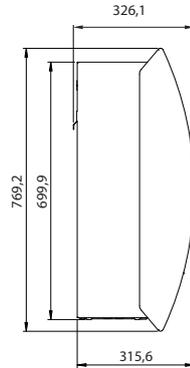
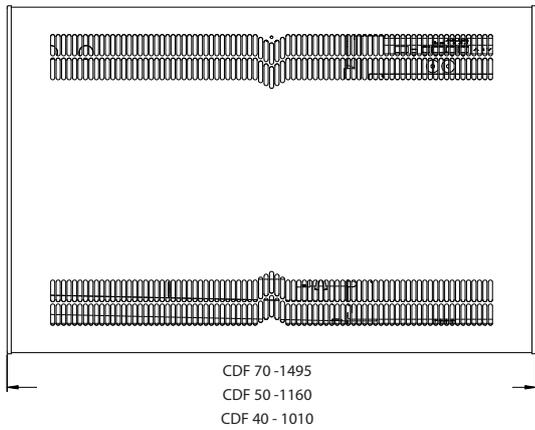

### Drain outlet position

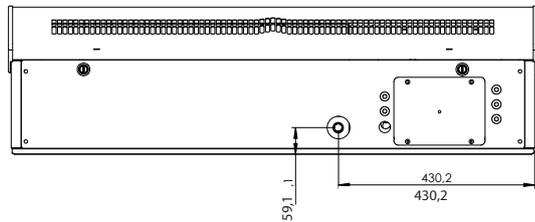

### Floor mounting kit

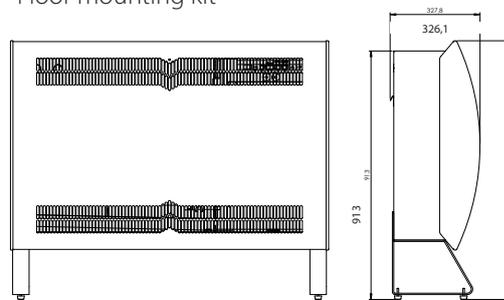

All measurements are in mm

### Performance data

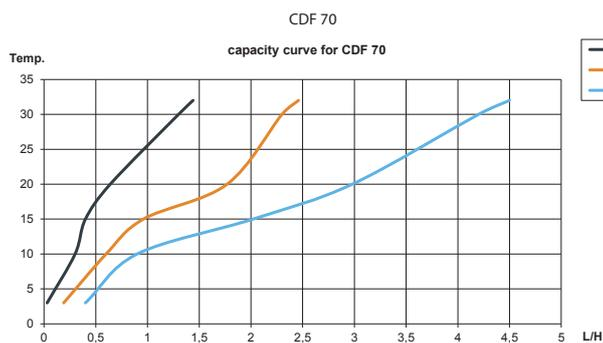
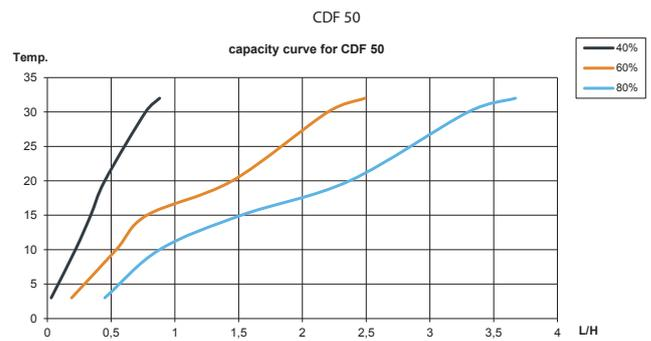
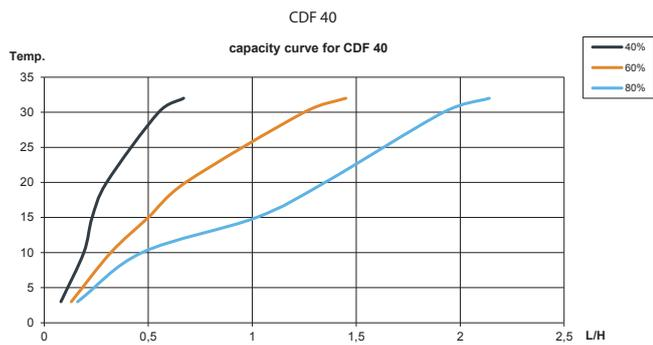

# LARGE CAPACITY DUCTED DEHUMIDIFIERS

## CDP 75-125-165



**CDP 75, CDP 125, CDP 165**

The CDP 75-125-165 condensation dehumidifiers have been designed for ducted installation in plant rooms for a wide range of commercial installations.

Renowned for their build quality and energy efficiency, the compact units can be wall-mounted or placed on the floor.

### Mounting

- CDP 75 and CDP 125 can be wall-mounted with a wall-mount kit
- CDP 75, CDP 125 and CDP 165 can be placed on the floor using a shock-absorbing floor mount kit (accessory)
- A water heating coil can be mounted in the air outlet duct for further heating of the dry air (accessory)

### Optional accessories



**Room hygrostat - 516301**



**Duct hygrostat - 516310**



**Room thermostat - 513321**

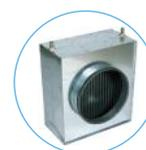

**Water heating coil - 570027, 570028, 570029**



**Shock-absorbing floor mounting kit - 175367, 175368, 175369**



**Wall mounting kit - 175381, 175382**



**Defrost sensor - 175401**



**Failure monitoring kit - 019401**

- The CDP 75-125-165 are built into a cabinet made of hot-galvanised, powder-painted and double-skinned panels with 50mm insulation
- Corrosion-protected evaporator and condenser coils
- The condensate outlet is located on the air inlet side
- The outlet stub can be connected to a water hose
- Air inlet through a filter placed in a removable frame
- Dry air outlet positioned either horizontally (through the side) or vertical (through the top) of the unit
- The access for inspection can be moved to the opposite side
- Fresh air (15%) inlet possible through fresh air duct
- Can be supplied with an optional water-cooled condenser
- Rotary/reciprocating compressor
- Radial fan

Specifications	Units	CDP 75	CDP 125	CDP 165
Operating temperature range	°C	20-38	20-38	20-38
Operating humidity range	%	40-100	40-100	40-100
Dehumidification @ 28°C/60% RH	l/24h	74	124	162
Air flow	m <sup>3</sup> /h	1,500	2,500	3,600
Power supply	V/Hz	230/1ph/50	230/1ph/50 + 400/3ph/50	400/3ph/50
Sound level	dB(A)	58	60	63
R407c gas weight/CO <sub>2</sub> equivalent	kg/t	2.1/3.73	5.2/9.22	6.8/12.06
Water-cooled condenser		Optional	Optional	Optional
Product size (w x d x h)	mm	1155 x 725 x 650	1300 x 900 x 850	1400 x 1010 x 975
Weight	kg	130	160	190

# LARGE CAPACITY DUCTED DEHUMIDIFIERS

## CDP 75-125-165



### CDP 75 dimensions

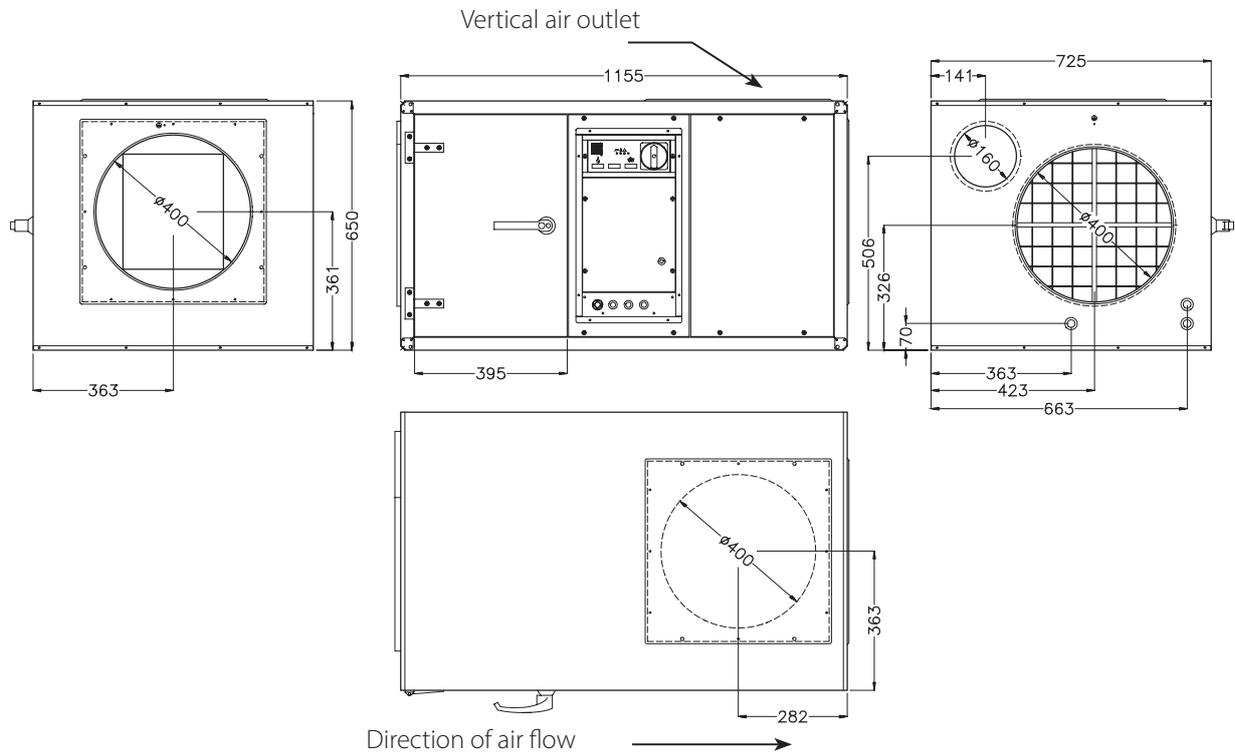

### CDP 125 dimensions

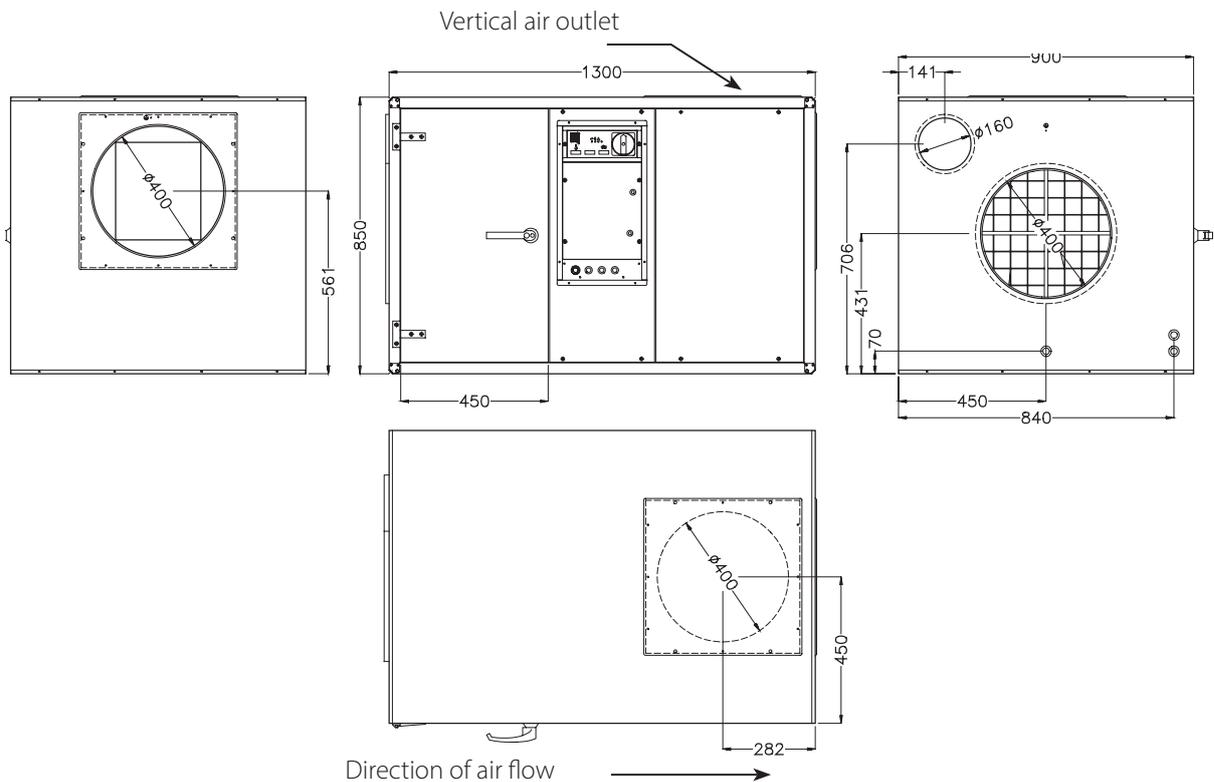

All measurements are in mm

# LARGE CAPACITY DUCTED DEHUMIDIFIERS

## CDP 75-125-165



### CDP 165 dimensions

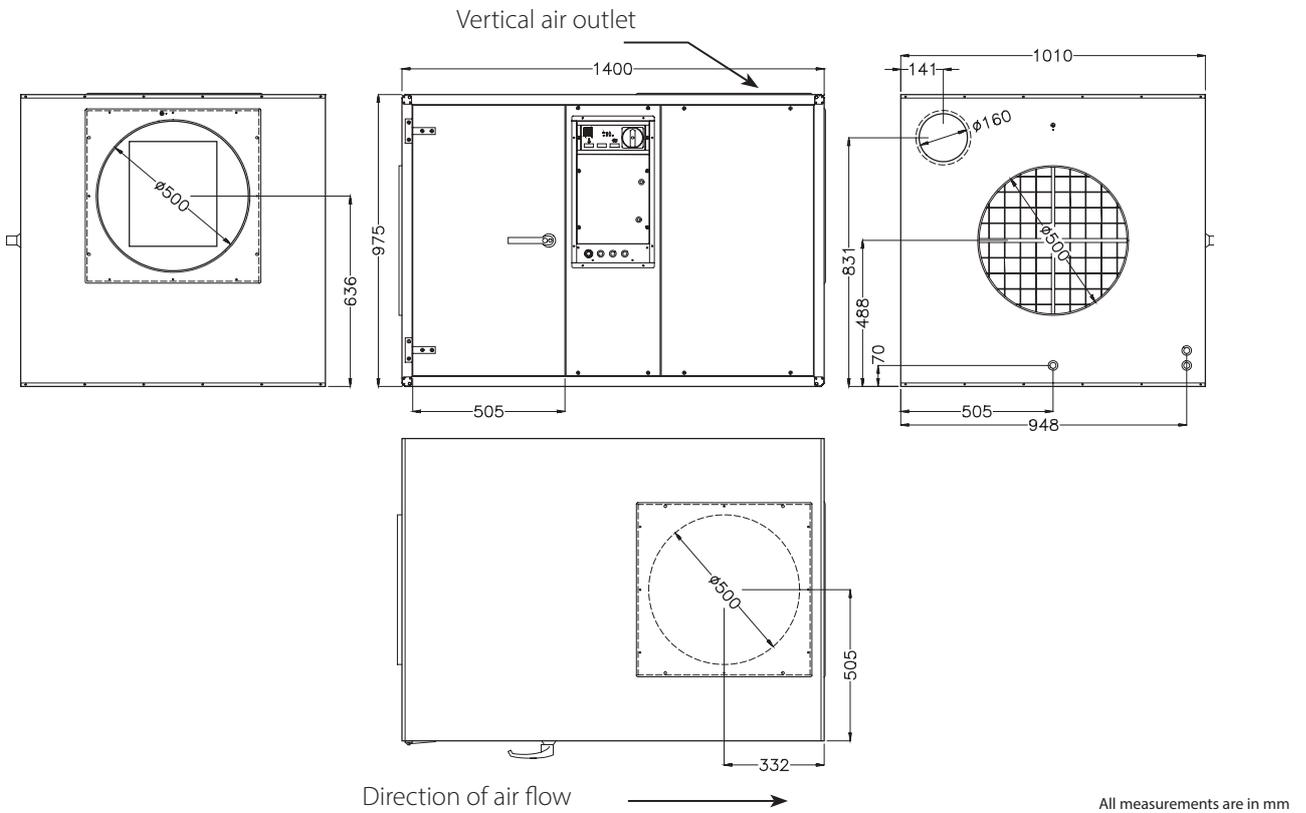

### Performance data

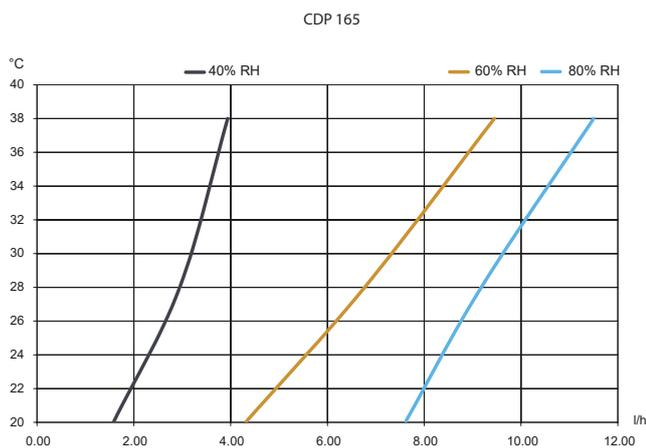
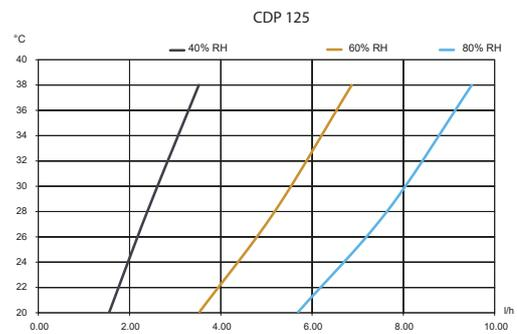
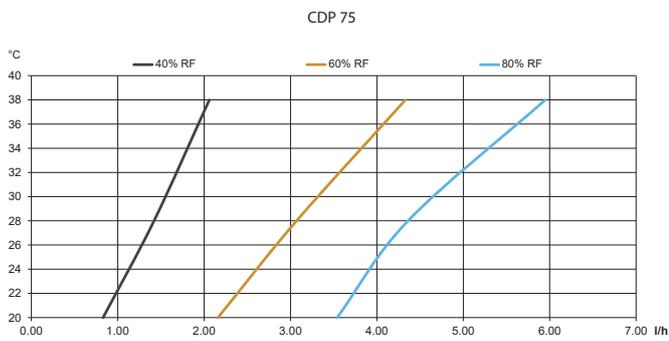

# LARGE CAPACITY DUCTED DEHUMIDIFIERS

## DANX AF



**DANX AF**

With its ability to significantly reduce the energy consumption, the DanX AF heat pump dehumidification system enables you to control humidity as well as indoor temperature in your building. Ideally suited for installation where space is limited, the system can even be installed suspended under the ceiling.

To reduce energy consumption even further, the DanX AF can be fitted with an optional water-cooled condenser. With this, the unit reuses all excess heat by transferring it to your hot water supply instead of letting it go to waste.



- User-friendly control system that monitors and controls temperature and humidity automatically. The custom-built software runs the unit as efficiently as possible under different conditions.
- BMS communication with either Modbus or BACnet. All internal terminal wiring done from factory.
- Refrigerant circuit with optional built-in water cooled condenser for heating of domestic water and external condenser for hot countries.
- Optional DX or water-cooling coil.
- Highly energy-efficient EC plug fans.
- Highly efficient bag filters with a low pressure drop.
- Fresh air (30%) inlet possible through fresh air duct.
- Load-bearing frame construction module with galvanised, powder-painted sandwich panels with 50mm mineral wool insulation and bottom frame with adjustable feet.
- Specifically designed to withstand the aggressive environments (Corrosion class C4 according to EN/ISO 12944-2), with epoxy coated, coils with aluminium frame, pre-painted fins and with all fasteners, bolts and nuts specially protected.
- Large inspection doors with strong hinges and tongue locks and handles for easy access for service.
- Modular unit for easy and quick installation with all sensors and electrical components already connected. Separate control panel fitted with cables and plugs for quick electrical connection between unit and panel.

Specifications	Units	AF 3/6	AF 5/10	AF 5/10s	AF 7/14	AF 7/14s	AF 12/24	AF 12/24s
Operating temperature range	°C	22-36	22-36	22-36	22-36	22-36	22-36	22-36
Operating humidity	%	50-80	50-80	50-80	50-80	50-80	50-80	50-80
Dehumidification @ 28°C/60% RH	l/h	13	20	25	33	39	52	62
Air flow	m³/h	4,850	7,300	9,500	12,000	14,000	19,000	24,000
External duct pressure	Pa	300	300	300	300	300	300	300
Outdoor air	%	0-30	0-30	0-30	0-30	0-30	0-30	0-30
Power supply	V/Hz	400/3ph/50	400/3ph/50	400/3ph/50	400/3ph/50	400/3ph/50	400/3ph/50	400/3ph/50
Max. power consumption	kW	8.6	12.3	16.1	22.1	24.1	31.7	42.8
R407c gas weight/CO <sub>2</sub> equivalent	kg/t	9/15.97	14/24.84	14/24.84	22/39.03	22/39.03	32/56.77	32/56.77
Height	mm	1115	1115	1115	1195	1195	1485	1485
Width	mm	3380	3380	3380	3850	3850	4125	4125
Depth	mm	880	1400	1400	1900	1900	2200	2200
Weight	kg	575	800	800	1125	1200	1650	1675

# LARGE CAPACITY DUCTED DEHUMIDIFIERS

## DANX AF



### DanX AF dimensions

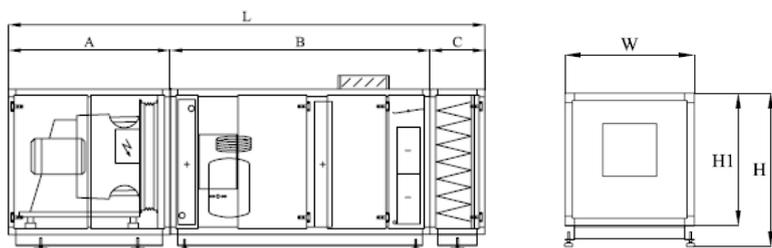

DanX AF	A: mm	B: mm	C: mm	L: mm	W: mm	H: mm	H1: mm	Weight: kg
3/6	985	1920	475	3380	880	1115	915	575
5/10	985	1920	475	3380	1400	1115	915	800
5/10s	985	1920	475	3380	1400	1115	915	800
7/14	1125	2250	475	3850	1900	1195	995	1125
7/14s	1125	2250	475	3850	1900	1195	995	1200
12/24	1400	2250	475	4125	2200	1485	1275	1650
12/24s	1400	2250	475	4125	2200	1485	1275	1675

### Performance data

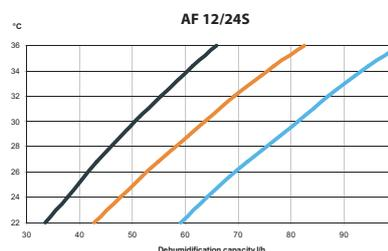
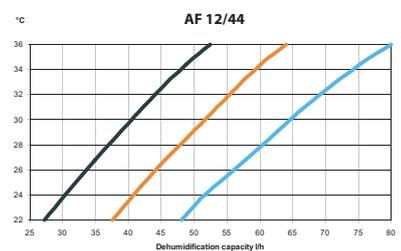
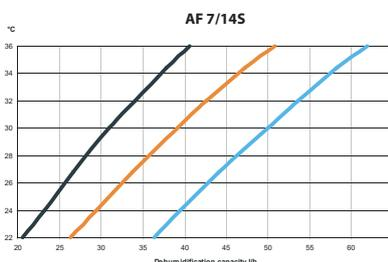
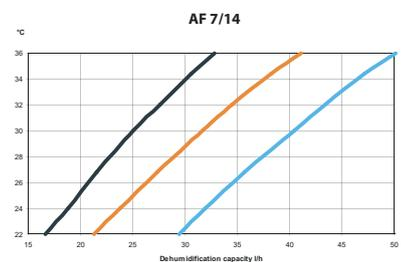
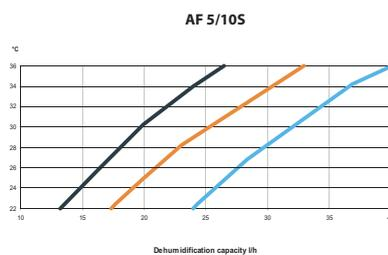
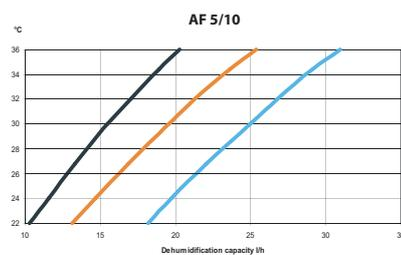
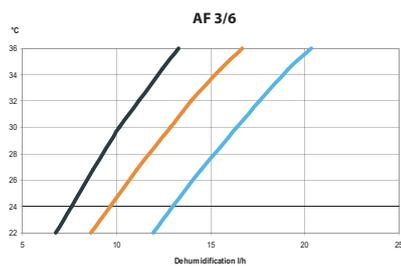

# ADSORPTION DEHUMIDIFIERS



# ADSORPTION DEHUMIDIFICATION SOLUTIONS FOR: FOOD AND AGRICULTURE, PHARMACEUTICAL & COLD STORAGE

## QUICK GUIDE



DRD 10-34-60



DRD 120-163  
-235-358



DRD 535-665-948  
-1188



DRD 1529-1963  
-2208-3146-3888

### INSTALLATION



WALL-MOUNTED



FLOOR STANDING



DUCTED



### APPLICATIONS



FOOD AND BEVERAGE



CONFECTIONARY



COLD ROOMS  
AND ICE RINKS



GREENHOUSES



PHARMACEUTICAL  
AND SCIENTIFIC



MILITARY AND  
AEROSPACE



LITHIUM BATTERIES



# ADSORPTION DEHUMIDIFICATION SOLUTIONS FOR: POWER PLANTS, GENERAL PRODUCTION & STORAGE

## QUICK GUIDE



DRD 10-34-60



DRD 120-163-235-358



DRD 535-665-948-1188



DRD 1529-1963-2208-3146-3888

### INSTALLATION



WALL-MOUNTED



FLOOR STANDING



DUCTED



### APPLICATIONS



POWER PLANTS



WATERWORKS



GENERAL INDUSTRY AND PRODUCTION



STORAGE, PRESERVATION AND ARCHIVES



DRY AIR STORAGE



MUSEUM AND GALLERY PRESERVATION



# SMALL AIR FLOW ADSORPTION DEHUMIDIFIERS

## DRD 10-34-60



**DRD 10**

Ideally suited for dehumidification tasks where space is limited, this range of small air flow adsorption dehumidifiers is characterised by its high performance due to two air inlets, two air outlets and two fans as well as robustness due to the insulated stainless-steel cabinet.

The dehumidifier range is suitable for several fields of application, in particular where space is limited. The stainless-steel housing with corrosion resistance class C5-I makes the units ideal for both hygienic and aggressive environments.

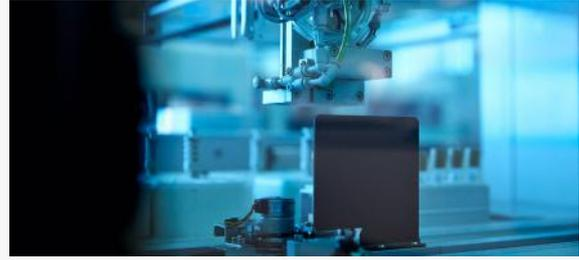

- Corrosion class for the interior is C3 (Aluzink 150, ISO 12944) and C5-I for stainless steel housing
- Single phase 50 or 60Hz
- Reactivation air in/out on same side
- Hour counter included as standard
- Coarse filter 60% (G4) for process and reactivation
- Effective dehumidification with very low dew-point, even under extreme conditions (-20°C/+40°C)
- Sturdy and non-flammable rotor capable of withstanding heat and saturated air
- The integrated alarm notifies you when filters are dirty and required replacement
- PLC control with intuitive touch-screen terminal and remote connection via RS485 or TCP/IP
- EC fans on process and regeneration air
- The units can be customised to your installation requirements on request

Specifications	Units	DRD 10	DRD 34	DRD 60
Dehumidification capacity @ 20°C/60% RH	kg/h	0.4	1.4	2.5
Process air flow	m <sup>3</sup> /h	90	300	450
Available pressure	Pa	150	200	200
Regeneration air flow	m <sup>3</sup> /h	25	75	120
Available pressure	Pa	150	150	200
Power consumption	kW	0.7	1.8	3.6
Power supply	V/Hz	230/1ph/50-60	230/1ph/50-60	400/3ph/50-60
Sound level*	dB(A)	42	44	46
Reactivation power	kW	0.6	1.7	3.3
Electric, steam		E/S	E/S	E/S
Filter	class	Coarse 60% (G4)	Coarse 60% (G4)	Coarse 60% (G4)
Product size (l x w x h)	mm	400 x 500 x 450	500 x 600 x 600	500 x 600 x 600
Weight	kg	25	32	33

# DRD 10-34-60



## Dimensions

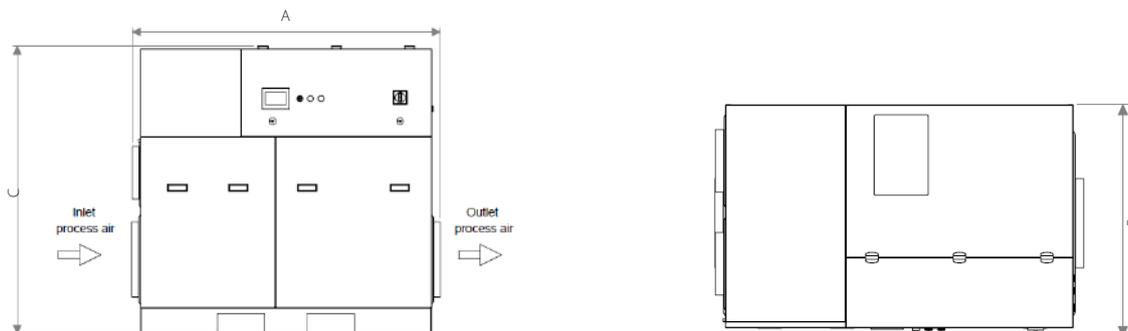

Dimensions	Units	DRD 10	DRD 34	DRD 60
A	mm	400	500	500
B	mm	500	600	600
C	mm	450	600	600

Part	Units	DRD 10	DRD 34	DRD 60
Process air inlet	Ømm	125	160	200
Dry air outlet	Ømm	125	160	200
Reactivation air inlet	Ømm	80	125	160
Wet air outlet	Ømm	80	125	160

## Performance data

**Legend**

- 40% RH
- 60% RH
- 80% RH

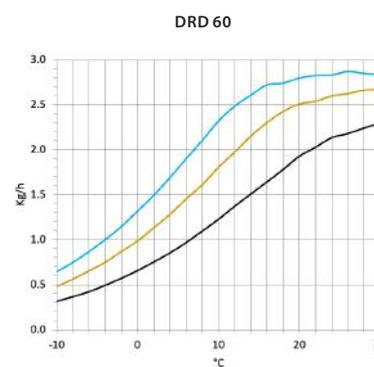
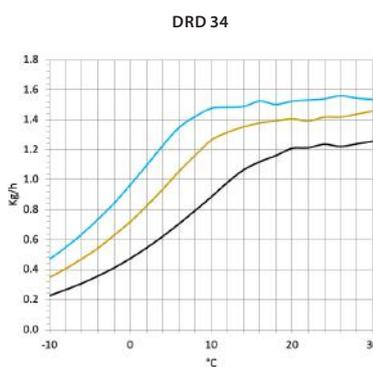
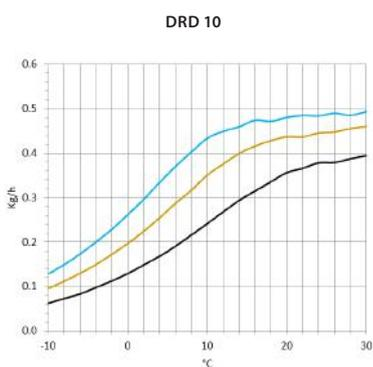

# MEDIUM AIR FLOW ADSORPTION DEHUMIDIFIERS

## DRD 120-163-235-358



**DRD 120**

This range of medium air flow and high-capacity adsorption dehumidifiers has been designed with an insulated stainless-steel casing for maximum robustness and with the regeneration inlet and outlet placed on the same side to simplify installation. The units are very suitable for several fields of application, including those that offer limited installation space. The stainless-steel used is corrosion resistance class C5-I, thus making the adsorption dehumidifiers ideal for both hygienic and aggressive environments.

Delivered with an advanced user interface and fully ready for site installation, the dehumidifiers need only be connected ducting before they are ready for operation.



- Corrosion class for the interior is C3 (Aluzink 150, ISO 12944) and C5-I for stainless steel housing
- Three-phase 50 or 60Hz
- Reactivation air in/out on same side
- Advanced user interface with RS485 and/or TCP/IP protocol
- Coarse filter 60% (G4) for process and reactivation
- Ventilated electric panel
- Effective dehumidification with very low dew-point, even under extreme conditions (-20°C/+40°C)
- Sturdy and non-flammable rotor capable of withstanding heat and saturated air
- The integrated alarm notifies you when filters are dirty and required replacement
- PLC control with intuitive touch-screen terminal and remote connection via RS485 or TCP/IP
- EC fans on process and regeneration air
- The units can be customised to your installation requirements on request

Specifications	Units	DRD 120	DRD 163	DRD 235	DRD 358
Dehumidification capacity @ 20°C/60% RH	kg/h	5.0	6.8	9.8	14.9
Process air flow	m <sup>3</sup> /h	800	1,100	1,300	2,300
Available pressure	Pa	200	400	350	180
Regeneration air flow	m <sup>3</sup> /h	250	370	400	680
Available pressure	Pa	200	350	300	400
Power consumption	kW	6.9	10.4	13.9	20.8
Power supply	V/Hz	400/3ph/50-60	400/3ph/50-60	400/3ph/50-60	400/3ph/50-60
Sound level*	dB(A)	65	66	68	68
Reactivation power	kW	6.6	9.7	13.2	19.8
Electric, steam		E/S	E/S	E/S	E/S
Filter	class	Coarse 60% (G4)	Coarse 60% (G4)	Coarse 60% (G4)	Coarse 60% (G4)
Product size (l x w x h)	mm	1300 x 800 x 1300	1300 x 800 x 1300	1400 x 900 x 1400	1400 x 900 x 1400
Weight	kg	220	230	320	330

\* Sound pressure level calculated in free field, 10m from unit, direction factor Q2, according to ISO 9614

# MEDIUM AIR FLOW ADSORPTION DEHUMIDIFIERS

## DRD 120-163-235-358



### Dimensions

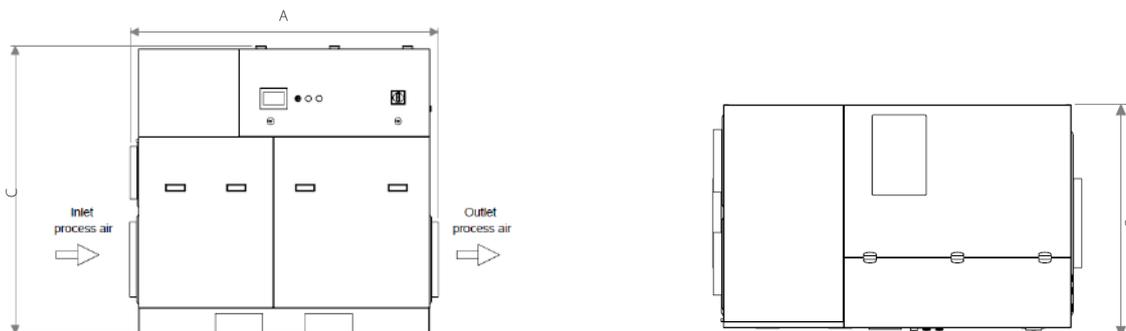

Dimensions	Units	DRD 120	DRD 163	DRD 235	DRD 358
A	mm	1300	1300	1400	1400
B	mm	800	800	900	900
C	mm	1300	1300	1400	1400

Parts	Units	DRD 120	DRD 163	DRD 235	DRD 358
Process air inlet	Ømm	315	315	355	355
Dry air outlet	Ømm	315	315	355	355
Reactivation air inlet	Ømm	160	160	250	250
Wet air outlet	Ømm	160	160	250	250

### Performance data

#### Legend

- 40% RH
- 60% RH
- 80% RH

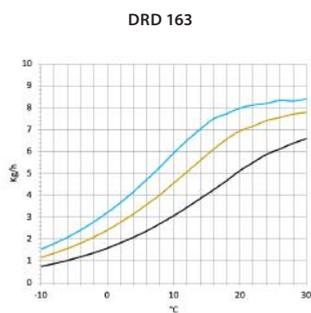
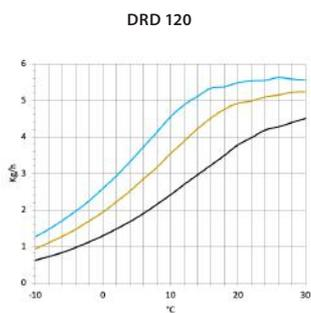

# LARGE AIR FLOW ADSORPTION DEHUMIDIFIERS

## DRD 535-665-948-1188



**DRD 535**



- Corrosion class for the interior is C3 (Aluzink 150, ISO 12944) and C5-I for stainless steel housing
- Three-phase 50 or 60Hz
- Reactivation air in/out on same side
- Advanced user interface with RS485 and/or TCP/IP protocol
- Coarse filter 60% (G4) for process and reactivation
- Ventilated electric panel
- Effective dehumidification with very low dew-point, even under extreme conditions (-20°C/+40°C)
- Sturdy and non-flammable rotor capable of withstanding heat and saturated air
- The integrated alarm notifies you when filters are dirty and required replacement
- PLC control with intuitive touch-screen terminal and remote connection via RS485 or TCP/IP
- EC fans on process and regeneration air
- The units can be customised to your installation requirements on request

This range of large air flow, high-capacity adsorption dehumidifiers has a cabinet built from robust insulated stainless steel. To simplify installation, regeneration inlets and outlets are placed on the same side.

Suitable for several fields of application, the compact units will fit nicely in installation areas that offer limited space. The stainless-steel housing with corrosion resistance class C5-I makes them ideal for both hygienic and aggressive environments.

The dehumidifiers come standard fitted with an advanced user interface and are fully prepared for site installation.

Specifications	Units	DRD 535	DRD 665	DRD 948	DRD 1188
Dehumidification capacity @ 20°C/60% RH	kg/h	22.3	27.7	39.5	49.5
Process air flow	m <sup>3</sup> /h	3,500	4,500	5,800	7,000
Available pressure	Pa	300	200	450	450
Regeneration air flow	m <sup>3</sup> /h	870	1,300	1,630	2,150
Available pressure	Pa	450	250	250	450
Power consumption	kW	30.0	37.5	54.0	67.5
Power supply	V/Hz	400/3ph/50-60	400/3ph/50-60	400/3ph/50-60	400/3ph/50-60
Sound level*	dB(A)	69	71	72	73
Reactivation power	kW	31.6	39.3	57.4	71.5
Electric, steam		E/S	E/S	E/S	E/S
Filter	class	Coarse 60% (G4)	Coarse 60% (G4)	Coarse 60% (G4)	Coarse 60% (G4)
Product size (l x w x h)	mm	1480 x 1110 x 1630	1480 x 1110 x 1630	1730 x 1395 x 1980	1730 x 1395 x 1980
Weight	kg	470	485	670	690

\* Sound pressure level calculated in free field, 10m from unit, direction factor Q2, according to ISO 9614

# LARGE AIR FLOW ADSORPTION DEHUMIDIFIERS

## DRD 535-665-948-1188



### Dimensions

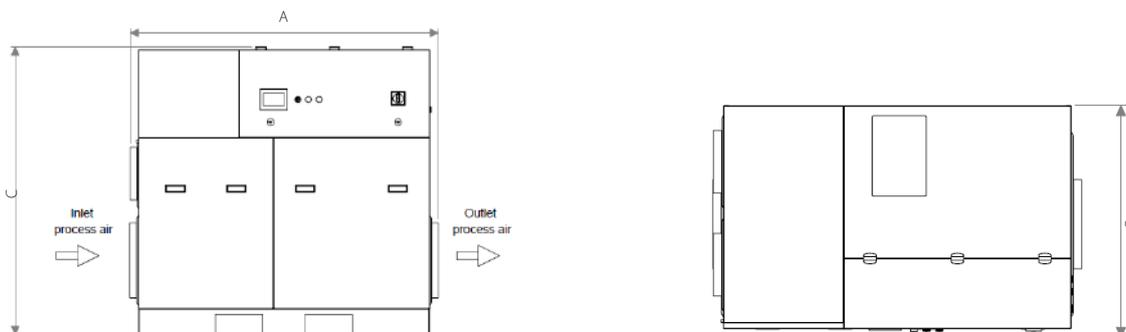

Dimensions	Units	DRD 535	DRD 665	DRD 948	DRD 1188
A	mm	1550	1600	1650	1800
B	mm	1050	1150	1350	1500
C	mm	1500	1650	1900	2100

Part	Units	DRD 535	DRD 665	DRD 948	DRD 1188
Process air inlet	Ømm	450	400	500	500 x2
Dry air outlet	Ømm	450	400	500	500 x2
Reactivation air inlet	Ømm	280	315	315	355
Wet air outlet	Ømm	280	315	315	355

### Performance data

#### Legend

- 40% RH
- 60% RH
- 80% RH

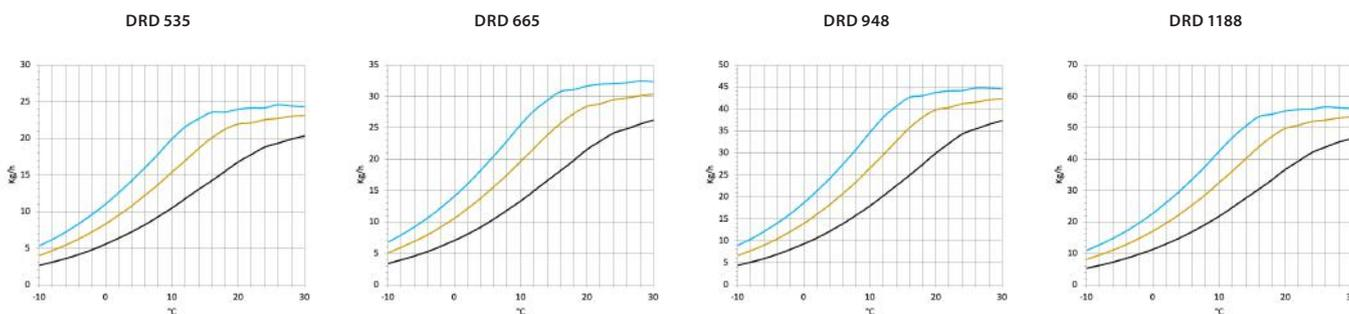

# EXTRA-LARGE AIR FLOW ADSORPTION DEHUMIDIFIERS

## DRD 1529-1963-2208-3146-3888



**DRD 1529**

These extra-large air flow, high-capacity adsorption dehumidifiers are manufactured with an insulated epoxy-painted casing and are fitted with an advanced controller interface as standard.

The range is highly suitable for all fields of application, especially those requiring extra high volumes of air to be treated.

The dehumidifiers are delivered pre-fitted with factory-mounted flanges. Once connected to ducting, they are ready for operation.



- Corrosion class for the interior is C3 (Aluzink 150, ISO 12944) and C4 for painted housing
- Three-phase 50 or 60Hz
- Reactivation air in/out on same side
- Advanced user interface with RS485 and/or TCP/IP protocol
- Coarse filter 60% (G4) for process and reactivation
- Ventilated electric panel
- Effective dehumidification with very low dew-point, even under extreme conditions (-20°C/+40°C)
- Sturdy and non-flammable rotor capable of withstanding heat and saturated air
- The integrated alarm notifies you when filters are dirty and required replacement
- PLC control with intuitive touch-screen terminal and remote connection via RS485 or TCP/IP
- EC fans on process and regeneration air
- The units can be customised to your installation requirements on request

Specifications	Units	DRD 1529	DRD 1963	DRD 2208	DRD 3146	DRD 3888
Dehumidification capacity @ 20°C/60% RH	kg/h	63.7	81.8	92.0	131.0	162.0
Process air flow	m³/h	9,000	11,000	13,000	19,000	25,000
Available pressure	Pa	400	400	400	400	400
Regeneration air flow	m³/h	2,700	3,700	4,300	5,500	7,900
Available pressure	Pa	400	400	400	400	400
Power consumption	kW	98.7	131.0	155.0	195.0	273.0
Power supply	V/Hz	400/3ph/50-60	400/3ph/50-60	400/3ph/50-60	400/3ph/50-60	400/3ph/50-60
Sound level*	dB(A)	72	74	74	76	76
Reactivation power	kW	90	120	144	180	252
Electric, steam		E/S	E/S	E/S	E/S	E/S
Filter	class	Coarse 60% (G4)	Coarse 60% (G4)	Coarse 60% (G4)	Coarse 60% (G4)	Coarse 60% (G4)
Product size (l x w x h)	mm	2350 x 1350 x 1750	3050 x 1600 x 1850	3050 x 1600 x 1850	3850 x 1950 x 2150	3850 x 1950 x 2150
Weight	kg	700	1350	1390	1980	2150

\* Sound pressure level calculated in free field, 10m from unit, direction factor Q2, according to ISO 9614

# EXTRA-LARGE AIR FLOW ADSORPTION DEHUMIDIFIERS

## DRD 1529-1963-2208-3146-3888



### Dimensions

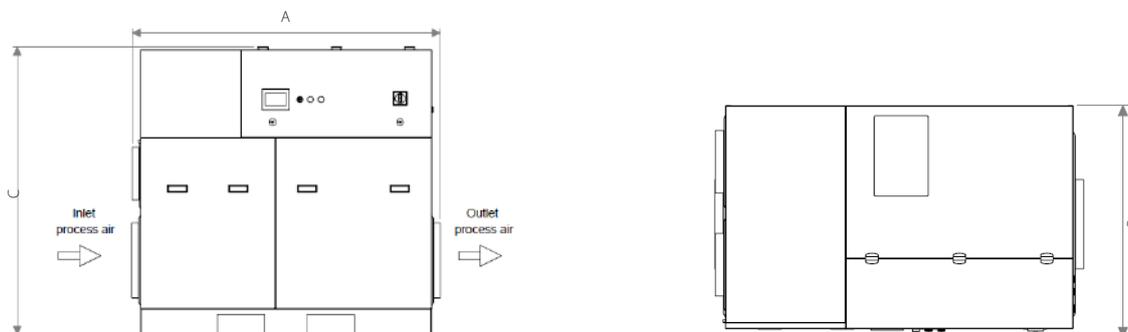

Dimensions	Units	DRD 1529	DRD 1963	DRD 2208	DRD 3146	DRD 3888
A	mm	2350	3050	3050	3850	3850
B	mm	1350	1600	1600	1950	1950
C	mm	1750	1850	1850	2150	2150

Part	Units	DRD 1529	DRD 1963	DRD 2208	DRD 3146	DRD 3888
Process air inlet	Ømm	1155 x 560	1250 x 600	1250 x 600	1500 x 800	1500 x 900
Dry air outlet	Ømm	1155 x 560	1250 x 600	1250 x 600	1500 x 800	1500 x 900
Reactivation air inlet	Ømm	560 x 460	600 x 600	600 x 600	800 x 800	800 x 800
Wet air outlet	Ømm	350	400	400	500	630

### Performance data

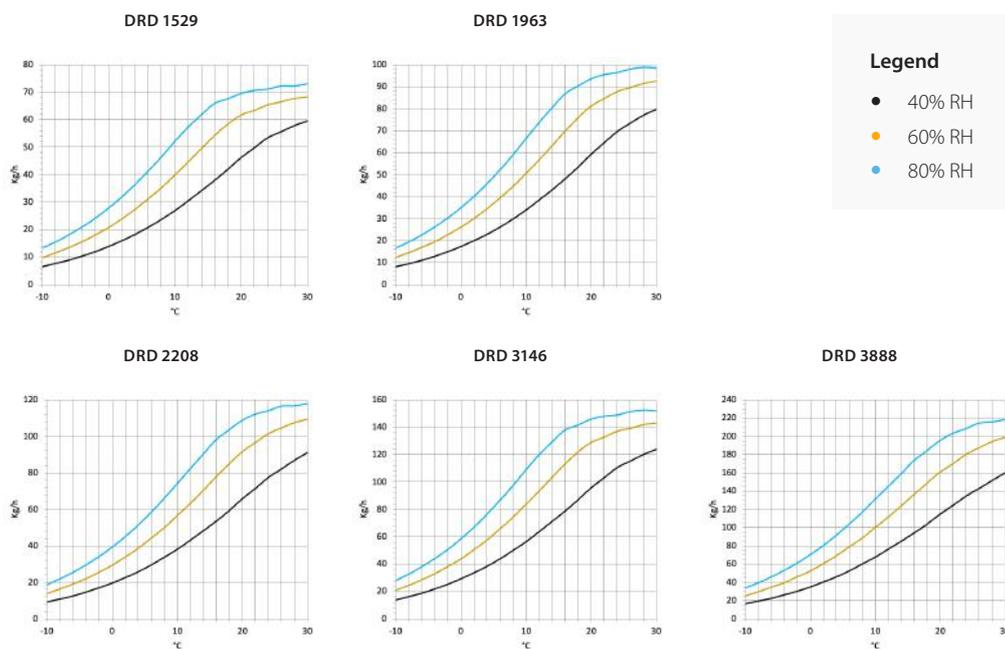

# ACCESSORIES



# ACCESSORIES

## CDP 40-50-70 | CDP 40T-50T-70T

Illustration	Accessory	Description	Products	Code
	<b>Remote control, DRC1</b>	<p>DRC1 is a wireless RH and temperature controller. Frequency: 433 mhz</p> <p>Range: Up to 50m depending on the conditions Protection class: IP20</p> <p><b>Functionalities:</b></p> <ul style="list-style-type: none"> <li>• Reading and setting of RH, temperature, alarms and service information</li> <li>• Locking of settings</li> </ul>	<p>CDP 40 CDP 50 CDP 70 CDP 40T CDP 50T CDP 70T</p>	<b>093455</b>
	<b>External RH/t sensor</b>	<p>Remote sensor with 10 meter wire Protection class: IPX7</p>	<p>CDP 40 CDP 50 CDP 70 CDP 40T CDP 50T CDP 70T</p>	<b>051710</b>
	<b>Floor mounting kit, 2 pcs</b>	<p>Each bracket to be mounted on each side of the dehumidifier</p>	<p>CDP 40 CDP 50 CDP 70</p>	<b>094322</b>
	<p><b>Water heating coil 2.6 kW*</b> <b>Water heating coil 4.2 kW*</b> <b>Water heating coil 6.2 kW*</b></p>	<p>Comprises water heating coil, flexible hose, fittings and gasket *at 80/60° C <i>(See technical specifications for water heating coils on separate page).</i></p>	<p>CDP 40, 40T CDP 50, 50T CDP 70, 70T</p>	<p><b>094333</b> <b>094334</b> <b>094335</b></p>
	<b>DN 10 control valve and actuator for water heating coils</b>	<p>Comprises valve and actuator 230 V, ON/OFF (180 seconds from closed to fully open), includes union nut for Ø 12 tube</p>	<p>CDP 40 CDP 50 CDP 70 CDP 40T CDP 50T CDP 70T</p>	<b>094340</b>
	<p><b>Electric heating coil 2 kW</b> <b>Electric heating coil 3.5 kW</b> <b>Electric heating coil 5 kW</b></p>	<p>Comprises electric heating coil, relays and electric wires</p>	<p>CDP 40, 40T CDP 50, 50T CDP 70, 70T</p>	<p><b>094336</b> <b>094337</b> <b>094338</b></p>

# ACCESSORIES

## CDP 40-50-70 | CDP 40T-50T-70T

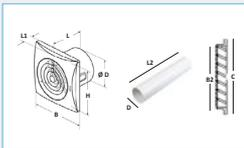
Illustration	Accessory	Description	Products	Code																														
	<b>Pro 30 Standard Exhaust fan</b>	<p>The exhaust fan can be used in combination with the CDP to either increase dehumidification capacity or establish outdoor air supply</p> <p><b>Pro 30 Standard:</b>            Power supply: 230 V/50Hz            Power consumption: 7.5W            Air volume: 97m³/h            Sound level: 25 dB(A)</p> <p><b>Pro 32 Standard:</b>            Power supply: 230 V/50Hz            Power consumption: 17W            Air volume: 185m³/h            Sound level: 32 dB(A)</p>	CDP 40 CDP 50 CDP 70 CDP 40T CDP 50T CDP 70T	<b>094339</b>																														
	<b>Pro 32 Standard Exhaust fan</b>	<p>Dimensions:</p> <table border="1"> <thead> <tr> <th></th> <th>Pro 30 Standard</th> <th>Pro 32 Standard</th> </tr> </thead> <tbody> <tr> <td><b>Ø D</b></td> <td>99</td> <td>124</td> </tr> <tr> <td><b>B</b></td> <td>158</td> <td>182</td> </tr> <tr> <td><b>H</b></td> <td>136</td> <td>158</td> </tr> <tr> <td><b>L</b></td> <td>107</td> <td>91</td> </tr> <tr> <td><b>L1</b></td> <td>26</td> <td>27</td> </tr> <tr> <td><b>D</b></td> <td>100</td> <td>125</td> </tr> <tr> <td><b>L2</b></td> <td>500</td> <td>500</td> </tr> <tr> <td><b>B2</b></td> <td>100</td> <td>125</td> </tr> <tr> <td><b>C</b></td> <td>125</td> <td>150</td> </tr> </tbody> </table>		Pro 30 Standard	Pro 32 Standard	<b>Ø D</b>	99	124	<b>B</b>	158	182	<b>H</b>	136	158	<b>L</b>	107	91	<b>L1</b>	26	27	<b>D</b>	100	125	<b>L2</b>	500	500	<b>B2</b>	100	125	<b>C</b>	125	150	CDP 40 CDP 50 CDP 70 CDP 40T CDP 50T CDP 70T	<b>094341</b>
	Pro 30 Standard	Pro 32 Standard																																
<b>Ø D</b>	99	124																																
<b>B</b>	158	182																																
<b>H</b>	136	158																																
<b>L</b>	107	91																																
<b>L1</b>	26	27																																
<b>D</b>	100	125																																
<b>L2</b>	500	500																																
<b>B2</b>	100	125																																
<b>C</b>	125	150																																
	<b>Through-wall duct kit with filter, extension kit and alu grill</b>	<p>Comprises inlet and outlet section, grills, inlet filter and extension</p> <p>For walls between 70 and 366mm thickness</p>	CDP 40T CDP 50T CDP 70T	<b>094271</b> <b>094243</b> <b>093508</b>																														
	<b>Duct lead-in adapter</b>	<p>The adapter makes it possible to place CDP 40T-50T-70T on the wall without changing the existing wall openings</p>	CDP 40T CDP 50T CDP 70T	<b>094801</b> <b>094802</b> <b>094804</b>																														

# ACCESSORIES

## CDP 40-50-70 | CDP 40T-50T-70T

Water heating coils – calculations at room temperature = 28°C; 60% RH

<b>CDP 40 + CDP 40T</b>	<b>Q = 400 m<sup>3</sup>/h</b>						
Water temperature	°C	82/71	80/60	70/35	90/70	60/40	55/45
Capacity	kW	3.32	2.64	0.68	3.4	1.02	1.36
Water flow rate	l/sec.	0.07	0.03	0.005	0.04	0.01	0.03
Water pressure drop	kPa	11.8	2.8	0.1	4.2	0.6	3.1
Water velocity	m/sec.	1.05	0.46	0.07	0.6	0.18	0.47
Air flow rate	m <sup>3</sup> /sec.	0.11	0.11	0.11	0.11	0.11	0.11
Inlet temperature	°C	82	80	70	90	60	55
Outlet temperature	°C	71	60	35	70	40	45
Air pressure drop	Pa	8	8	8	8	8	8
Connection tube	Ømm	12	12	12	12	12	12

<b>CDP 50 + CDP 50T</b>	<b>Q = 680 m<sup>3</sup>/h</b>						
Water temperature	°C	82/71	80/60	70/35	90/70	60/40	55/45
Capacity	kW	5.28	4.27	0.99	5.45	1.82	2.2
Water flow rate	l/sec.	0.12	0.05	0.01	0.07	0.02	0.05
Water pressure drop	kPa	32.3	7.6	0.2	11.6	1.8	8.6
Water velocity	m/sec.	1.68	0.74	0.1	0.95	0.32	0.76
Air flow rate	m <sup>3</sup> /sec.	0.19	0.19	0.19	0.19	0.19	0.19
Inlet temperature	°C	82	80	70	90	60	55
Outlet temperature	°C	71	60	35	70	40	45
Air pressure drop	Pa	10	10	10	10	10	10
Connection tube	Ømm	12	12	12	12	12	12

<b>CDP 70 + CDP 70T</b>	<b>Q = 900 m<sup>3</sup>/h</b>						
Water temperature	°C	82/71	80/60	70/35	90/70	60/40	55/45
Capacity	kW	7.56	6.23	2.37	7.9	2.83	3.23
Water flow rate	l/sec.	0.17	0.08	0.02	0.1	0.03	0.08
Water pressure drop	kPa	83	20.1	1.5	30.1	5.3	22.9
Water velocity	m/sec.	2.4	1.09	0.23	1.38	0.49	1.12
Air flow rate	m <sup>3</sup> /sec.	0.25	0.25	0.25	0.25	0.25	0.25
Inlet temperature	°C	82	80	70	90	60	55
Outlet temperature	°C	71	60	35	70	40	45
Air pressure drop	Pa	8	8	8	8	8	8
Connection tube	Ømm	12	12	12	12	12	12

# ACCESSORIES

## CDP 75-125-165

Illustration	Accessory	Products	Code
	<b>Room hygostat</b>	CDP 75 CDP 125 CDP 165	<b>516301</b> <b>516301</b> <b>516301</b>
	<b>Room thermostat</b>	CDP 75 CDP 125 CDP 165	<b>513321</b> <b>513321</b> <b>513321</b>
	<b>Duct hygostat</b>	CDP 75 CDP 125 CDP 165	<b>516310</b> <b>516310</b> <b>516310</b>
	<b>Wall mounting kit</b>	CDP 75 CDP 125	<b>175381</b> <b>175382</b>
	<b>Shock-absorbing floor mount kit</b>	CDP 75 CDP 125 CDP 165	<b>175367</b> <b>175368</b> <b>175369</b>
	<b>Water heating coil</b>	CDP 75 CDP 125 CDP 165	<b>570027</b> <b>570028</b> <b>570029</b>
	<b>Defrost sensor</b>	CDP 75 CDP 125 CDP 165	<b>175401</b> <b>175401</b> <b>175401</b>
	<b>External failure monitoring kit</b>	CDP 75 CDP 125 CDP 165	<b>019401</b> <b>019401</b> <b>019401</b>

# ACCESSORIES

## CDF 10-40-50-70

Illustration	Accessory	Description	Products	Code
	<b>Water tank</b>	White or grey	CDF 10	<b>351615 – White tank</b> <b>351616 – Grey tank</b>
	<b>Remote control, DRC1</b>	DRC1 is a wireless RH and temperature controller. Frequency: 433 mhz  Range: Up to 50m depending on the conditions Protection class: IP20  <b>Functionalities:</b> <ul style="list-style-type: none"> <li>• Reading and setting of RH, temperature, alarms and service information</li> <li>• Locking of settings</li> </ul>	CDF 40 CDF 50 CDF 70	<b>093455</b>
	<b>External RH/t sensor</b>	Remote sensor with 10 meter wire  Protection class: IPX7	CDF 40 CDF 50 CDF 70	<b>051710</b>
	<b>Floor mounting kit, 2 pcs - black</b>	Each bracket to be mounted on each side of the dehumidifier	CDF 40 CDF 50 CDF 70	<b>094332</b>
	<b>Water heating coil 2.6 kW*</b> <b>Water heating coil 4.2 kW*</b> <b>Water heating coil 6.2 kW*</b>	Comprises water heating coil, flexible hose, fittings and gasket  *at 80/60° C  <i>(See technical specifications for water heating coils on separate page).</i>	CDF 40 CDF 50 CDF 70	<b>094333</b> <b>094334</b> <b>094335</b>
	<b>DN 10 control valve and actuator for water heating coils</b>	Comprises valve and actuator 230 V, ON/OFF (180 seconds from closed to fully open), includes union nut for Ø 12 tube	CDF 40 CDF 50 CDF 70	<b>094340</b>
	<b>Electric heating coil 2 kW</b> <b>Electric heating coil 3.5 kW</b> <b>Electric heating coil 5 kW</b>	Comprises electric heating coil, relays and electric wires	CDF 40 CDF 50 CDF 70	<b>094336</b> <b>094337</b> <b>094338</b>

# ACCESSORIES

## CDF 10-40-50-70

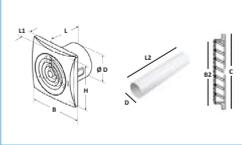
Illustration	Accessory	Description	Products	Code																														
	<b>Pro 30 Standard Exhaust fan</b>	<p>The exhaust fan can be used in combination with the CDP to either increase dehumidification capacity or establish outdoor air supply.</p> <p><b>Pro 30 Standard:</b>            Power supply: 230 V/50Hz            Power consumption: 7.5W            Air volume: 97m<sup>3</sup>/h            Sound level: 25 dB(A)</p>	CDF 40 CDF 50 CDF 70	<b>094339</b>																														
	<b>Pro 32 Standard Exhaust fan</b>	<p>Dimensions:</p> <table border="1"> <thead> <tr> <th></th> <th>Pro 30 Standard</th> <th>Pro 32 Standard</th> </tr> </thead> <tbody> <tr> <td><b>Ø D</b></td> <td>99</td> <td>124</td> </tr> <tr> <td><b>B</b></td> <td>158</td> <td>182</td> </tr> <tr> <td><b>H</b></td> <td>136</td> <td>158</td> </tr> <tr> <td><b>L</b></td> <td>107</td> <td>91</td> </tr> <tr> <td><b>L1</b></td> <td>26</td> <td>27</td> </tr> <tr> <td><b>D</b></td> <td>100</td> <td>125</td> </tr> <tr> <td><b>L2</b></td> <td>500</td> <td>500</td> </tr> <tr> <td><b>B2</b></td> <td>100</td> <td>125</td> </tr> <tr> <td><b>C</b></td> <td>125</td> <td>150</td> </tr> </tbody> </table>		Pro 30 Standard	Pro 32 Standard	<b>Ø D</b>	99	124	<b>B</b>	158	182	<b>H</b>	136	158	<b>L</b>	107	91	<b>L1</b>	26	27	<b>D</b>	100	125	<b>L2</b>	500	500	<b>B2</b>	100	125	<b>C</b>	125	150	CDF 40 CDF 50 CDF 70	<b>094341</b>
	Pro 30 Standard	Pro 32 Standard																																
<b>Ø D</b>	99	124																																
<b>B</b>	158	182																																
<b>H</b>	136	158																																
<b>L</b>	107	91																																
<b>L1</b>	26	27																																
<b>D</b>	100	125																																
<b>L2</b>	500	500																																
<b>B2</b>	100	125																																
<b>C</b>	125	150																																

# ACCESSORIES

## CDF 10-40-50-70

Water heating coils – calculations at room temperature = 20°C; 50% RH

<b>CDF 40</b>	<b>Q=400 m<sup>3</sup>/h</b>						
Water temperature	°C	82/71	80/60	70/35	90/70	60/40	55/45
Capacity	kW	3.85	3.19	1.16	3.94	1.64	1.91
Water flow rate	l/sec.	0.09	0.04	0.01	0.05	0.02	0.05
Water pressure drop	kPa	15.5	3.9	0.3	5.5	1.3	5.7
Water velocity	m/sec.	1.22	0.56	0.11	0.69	0.28	0.66
Air flow rate	m <sup>3</sup> /sec.	0.11	0.11	0.11	0.11	0.11	0.11
Inlet temperature	°C	82	80	70	90	60	55
Outlet temperature	°C	71	60	35	70	40	45
Air pressure drop	Pa	8	8	8	8	8	8
Connection tube	mm	12	12	12	12	12	12

<b>CDF 50</b>	<b>Q=680 m<sup>3</sup>/h</b>						
Water temperature	°C	82/71	80/60	70/35	90/70	60/40	55/45
Capacity	kW	6.11	5.12	2.42	6.29	2.75	3.08
Water flow rate	l/sec.	0.14	0.06	0.02	0.08	0.03	0.08
Water pressure drop	kPa	42.2	10.6	1.1	14.9	3.8	15.6
Water velocity	m/sec.	1.94	0.06	0.24	1.1	0.48	1.07
Air flow rate	m <sup>3</sup> /sec.	0.19	0.19	0.19	0.19	0.19	0.19
Inlet temperature	°C	82	80	70	90	60	55
Outlet temperature	°C	71	60	35	70	40	45
Air pressure drop	Pa	10	10	10	10	10	10
Connection tube	mm	12	12	12	12	12	12

<b>CDF 70</b>	<b>Q=900 m<sup>3</sup>/h</b>						
Water temperature	°C	82/71	80/60	70/35	90/70	60/40	55/45
Capacity	kW	8.74	7.43	3.86	9.07	4.12	4.47
Water flow rate	l/sec.	0.19	0.09	0.03	0.11	0.05	0.11
Water pressure drop	kPa	108.1	27.7	3.4	38.7	10.3	40.7
Water velocity	m/sec.	2.78	1.3	0.38	1.59	0.71	1.55
Air flow rate	m <sup>3</sup> /sec.	0.25	0.25	0.25	0.25	0.25	0.25
Inlet temperature	°C	82	80	70	90	60	55
Outlet temperature	°C	71	60	35	70	40	45
Air pressure drop	Pa	8	8	8	8	8	8
Connection tube	mm	12	12	12	12	12	12

# ACCESSORIES

## DANX

Illustration	Accessory	Description	Products	Code
	<b>DanX touchscreen</b>		DANX 1-2-3, HP, AF, CF	<b>490146</b>

## CD 15

Illustration	Accessory	Description	Products	Code
	<b>Replacement air filter</b>	Replacement	CD 15	<b>490146</b>
	<b>Condensate drainage hose</b>	Size: 12 x 2 mm	CD 15	<b>490100</b>

# ACCESSORIES

## DRD

We offer a variety of accessories, including the below.

Illustration	Accessory	Description	Products	Code
	<b>Duct probe</b>	RH% + temp. range 0-100% / -30°/70°C (4..20mA - 24Vac/dc)	All DRD products	<b>H1D</b>
	<b>Wall probe</b>	RH% + temp. range 0-100% / -30°/70°C (4..20mA - 24Vac/dc)	All DRD products	<b>H1W</b>
	<b>Wall probe</b>	RH% + temp. range 10-90% / 0°/50°C (4..20mA - 24Vdc)	All DRD products	<b>H2W</b>
	<b>Electronic humidistat</b>	Electronic humidistat for wall 1 step + 1 alarm + ModBus power supply 230Vac	All DRD products	<b>HW230</b>
	<b>Electronic humidistat</b>	Electronic humidistat for wall 0/10Vdc + 1 alarm + ModBus power supply 24Vdc	All DRD products	<b>HW24</b>
	<b>Probe duct</b>	Probe duct Dew-point range -60°/20°C (4..20mA - 24Vdc)	All DRD products	<b>HDWP</b>

# GLOSSARY

## **Prefix = type of heat pump or product**

HPP-i	Heat pump pool-inverter
CDF	Dehumidifier, fixed installation
CDP	Dehumidifier, pool installation
DanX	Swimming pool AHUs

## **Suffix = model type**

For example

-T	CDP through-the-wall version
----	------------------------------

## **DanX 1, DanX 2, DanX 3**

XD	Double crossflow heat exchanger only
HP	Double crossflow heat exchanger and heat pump

## **DanX XWPS**

X	Crossflow heat exchanger
WP	Heat pump
S	Swimming pools

## **DanX XWPRS**

X	Crossflow heat exchanger
WP	Heat pump
R	Reversible
S	Swimming pools

## **DanX XKS**

X	Crossflow heat exchanger
K	Crossflow heat exchanger only
S	Swimming pools

## **DanX CF**

CF	Counter flow heat exchanger
----	-----------------------------

## **DanX AF/AFs**

AF	Heat pump dehumidifier, no crossflow heat exchanger
s	Larger compressor and more airflow, higher dehumidification capacity, contained in the same dimensions as the 'non s' version.

## **Number = size of product**

For example

CDP	40, 50, 70, 75, 125, 165
DanX XD/HP	1, 2, 3
DanX AF	3/6, 5/10, 5/10s, 7/14, etc.
DanX XKS	2/4, 3/6, 5/10, 7/14, etc.

## **DanX numbering system**

Numbers indicate air flow, so a 2/4 is from 2000 m<sup>3</sup>/h to 4000 m<sup>3</sup>/h. The actual nominal air flow is stated in the documentation and brochures.

XWPS-XWPRS/XKS 2/4 = 2000/4000

XWPS-XWPRS/XKS 3/6 = 3000/6000

XWPS-XWPRS/XKS 5/10 = 5000/10000

XWPS-XWPRS/XKS 7/14 = 7000/14000

XWPS-XWPRS/XKS 9/18 = 9000/18000

XWPS-XWPRS/XKS 12/24 = 12000/24000

XWPS-XWPRS/XKS 16/32 = 16000/32000

**NOTE:** On an AF the same numbering system is used, but the air flow cannot be changed. The actual nominal air flow is stated in the documentation and brochures.

AF 3/6 = 3000/6000

AF/AFs 5/10 = 5000/10000

AF/AFs 7/14 = 7000/14000

AF/AFs 12/24 = 12000/24000



**Dantherm A/S**

Marienlystvej 65  
DK-7800 Skive  
Denmark  
t. +45 96 14 37 00

**Dantherm Ltd.**

Unit 12, Galliford Road  
Maldon CM9 4XD  
United Kingdom  
t. +44 (0)1621 856611

**Dantherm GmbH**

Oststraße 148  
22844 Norderstedt  
Germany  
t. +49 40 526 8790

**Dantherm S.p.A.**

Via Gardesana 11  
37010 Pastrengo (VR)  
Italy  
t. +39 045 6770533

**Dantherm Sp. z o.o.**

ul. Magazynowa 5a  
62-023 Gądki  
Poland  
t. +48 61 65 44 000

**Dantherm SP S.A.**

C/Calabozos 6  
(Polígono Industrial)  
28108 Alcobendas, Madrid  
Spain  
t. +34 91 661 45 00

**Dantherm SAS**

23 rue Eugène Hénaff  
69694 Vénissieux Cedex  
France  
t. +33 4 78 47 11 11

**Dantherm AS**

Løkkeåsveien 26  
3138 Skallestad  
Norway  
t. +47 33 35 16 00

**Dantherm AB**

Fridhemsvägen 3  
602 13 Norrköping  
Sweden  
t. +46 (0)11 19 30 40

**Dantherm LLC**

Transportnaya 22/2  
142800, Stupino  
Moscow  
Russia  
t. +7 (495) 642 444 8

**MCS China**

Unit 2B, No. 512  
Yunchuan Road  
Baoshang, Shanghai, 201906  
China  
t. +8621 61486668

**AirCenter AG**

Täferstrasse 14  
CH-5405 Baden Dättwil  
Switzerland  
t. +41 43 500 00 50

**Heylo GmbH**

Im Finigen 9  
28832 Achim  
Germany  
t. +49 4202 97550

**SET Energietechnik GmbH**

August-Blessing-Straße 5  
71282 Hemmingen  
Germany  
t. +49 7150 94540

Dealer:

KEEP UPDATED  
**FOLLOW US ON:**

